



15.6" AMOLED

3840*2160

LCD196-156NTL0NCNTTR0.1

lincolntechnologies.com • 111 Corning Rd. STE 116 • Cary, NC 27518

www.lincolntechnologies.com

©2021 All rights reserved.

Contents

Revision History	3
1. Scope.....	3
2. Features.....	3
3. General Information.....	4
4. Maximum Rating	4
5. Mechanical Specifications	5
6. Electrical Specifications	5
7. Electro-Optical Specification.....	6
8. I/O connection & Block Diagram	11
9. Recommended Operating Sequence	12
10. Interface	13
11. Reliability	13
12. Handling Precautions	13
14. Packing Specification.....	14
15. The Control of Hazardous substances	14

Lincoln Technology Solutions Confidential

Revision History

Version History			
Version. No	Date	Contents	Remark
1	12/13/2021	Preliminary Specification	
2	5/20/2022	Corrected part Revision in the preliminary specification to 0.1	

1. Scope

This Specification defines AMOLED manufactured Lincoln Technology Solutions, from here on referred to as LTS. In the case of any unspecified item, it may require both LTS and the party designs this module into its product to work out a solution.

2. Features

2.1 Product Applications

Laptop/Notebook

2.2 Product Features

- 1) Display color: RGB 10bit
- 2) Display format: 15.6" (3840RGBx2160)
- 3) Pixel arrangement: Real RGB arrangement
- 4) Interface: eDP 1.4b
- 5) T-con: MTK
- 6) Source IC: RM98110
- 7) Power IC:
RM/Chipone

2.3 Model Name:

Code	Definition	Description
E	Supplier Name	LTS
156	Display Size	15.60 inch
U	Resolution	3840RGB×2160
B	Technology	LTPS/Real RGB/0.3mm glass
A	Touch technology	NA
6	Delivery type	FOG
A	serial number	A

3. General Information

Item	Specification	Unit	Note
Active area	344.2176 (H) x 193.6224 (V)	mm	
Diagonal size	15.6	inch	
Driver Element	LTPS TFT active matrix		
Display mode	OLED		
Display Colors	RGB 10 bit		
Number of pixel	3840*2160(UHD)	Pixel	16:9
Pixel Arrangement	RGB Delta Type		
Pixel pitch	89.64x89.6	μm	
Surface treatment	Glare		

4. Maximum Rating

Item		Symbol	Min.	Max.	Unit	Note
Storage temperature		TSTG	-40	85	°C	-
Operating temperature		TOPR	-20	70	°C	-
Supply Voltage	System	VDD_3.3V	-0.3	+4.6	V	-
	EL Power	VBAT	-0.3	+27	V	-

5. Mechanical Specifications

Item		Min.	Typ.	Max.	Unit	Note
Module Size	Horizontal (H)	348.02	348.22	348.42	mm	
	Vertical (V)	215.172	215.672	216.172	mm	w/ PCB
	Thickness (Panel)	-	1.102	1.215	inch	
	Thickness w/ PCB			2.804	mm	
Weight				200	g	

6. Electrical Specifications

Item		Symbol	Condition	Min.	Typ.	Max.	Unit	Note
System	Analog/ Logic Vol.	VDD_3.3V	-	3.0	3.3	3.6	V	
Panel	Analog Vol.	VBAT	-	8.0	12.0	21.0	V	
Current	Logic	VDD_3.3V	Full white VDD_3.3V =3.3V VBAT=12V	-	420	640	mA	(1)
	Panel	IVBAT		-	1100	1370		
Consumption	Logic	VDD_3.3V		-	1.4	2.1	W	(1)
	Panel	PVBAT		-	13.2	16.4		
Frame Frequency		fps	-	-	60	-	Hz	

Note (1): VDD_3.3V=3.3 (V) VBAT=12.0 (V), Full White pattern, Temperature = 22±3°C Room Temperature

7. Electro-Optical Specification

Test condition: 25°C±3°C, 65±20%RH, Dark room.

Item	Symbol	Condition	Min.	Typ.	Max.	Unit	Note
Brightness		Normal (White mode)	352	400	448	cd/m ²	(1)
Peak Luminance (10% Box)		VESA HDR	500	-	-	cd/m ²	VESA HDR
Brightness Uniformity		Full white	75	-	-	%	(2)
Contrast Ratio		Normal $\theta=\Phi=0^\circ$	100,000	-	-	-	(3)
Color of CIE Coordinate	White	x	0.293	0.313	0.333	-	
		y	0.309	0.329	0.349	-	
	Red	x	0.658	0.688	0.718	-	
		y	0.282	0.312	0.342	-	
	Green	x	0.18	0.22	0.26	-	
		y	0.696	0.736	0.776	-	
	Blue	x	0.105	0.145	0.185	-	
		y	0.021	0.041	0.081	-	
Color Gamut		Adobe RGB	98	-	-	%	(4)
		DCI-P3	98	-	-	%	
White Temperature K		Normal $\theta=\Phi=0^\circ$	6000	6500	7000	K	
Gamma		Normal $\theta=\Phi=0^\circ$	2.0	2.2	2.4	-	(5)
Response time		On/Off	-	1	2	ms	(6)
Viewing Angle		Top/Bottom/Right/ Left CR>10	85	-	-	°	(7)
Color Shift	Δuv	$\theta=\Phi=45^\circ$	-	-	0.025	-	(8)
Image Sticking	ΔE	Macbeth pattern Max Lum, 3000h	-	-	3.5	%	(9)
Flicker		Normal $\theta=\Phi=0^\circ$	-	-	-30	dB	

Crosstalk	Normal $\theta = \Phi = 0^\circ$	-	-	1.5	%	(10)
TUV blue ray certification	415-455nm/400-500nm			50	%	(11)
OLED Lifetime	T50 @ 25°C	15,000	-	-	Hrs	(12)

Note 1: Brightness follows MicroSoft brightness3 (Based on OPR 50%). The Brightness of full white pattern (OPR100%) is the same as that of OPR 50%.



Note 2: Brightness uniformity

For brightness uniformity measure, LTS' request as below:

1. The test condition is at 25°C and measured on the surface of Display panel module.
2. Measurement equipment: CA310 or similar equipment.
3. The brightness uniformity is calculated by using following formula: Brightness Uniformity =

$$B_p (\text{Min.}) / B_p (\text{Max.}) \times 100 (\%)$$

$B_p (\text{Max.})$ = Maximum brightness in 13 measured spots

$B_p (\text{Min.})$ = Minimum brightness in 13 measured spots.

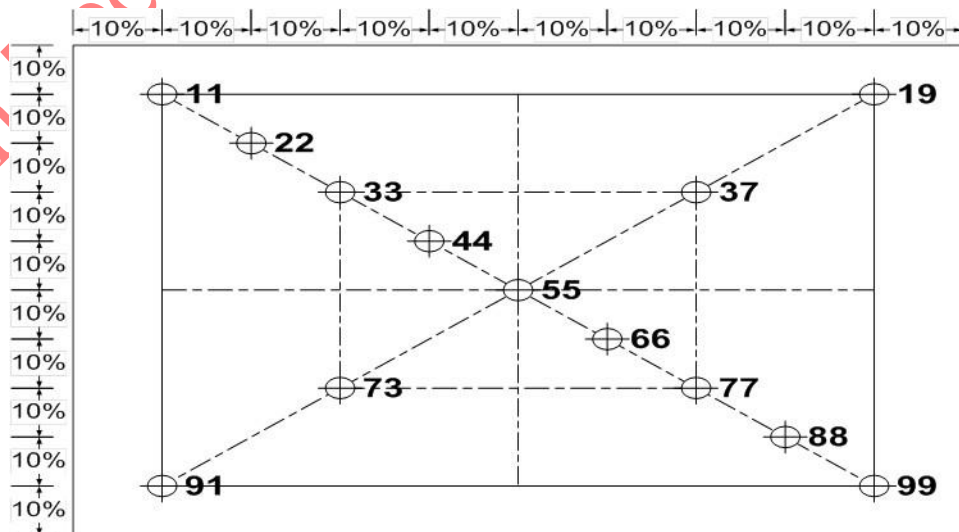

Note 3: Contrast Ratio

Dark Room C.R=LW/LB

LW: full white brightness of display center P0; LB: full black brightness of display center P0.

Note 4: Color Gamut

For brightness uniformity measure, LTS' request as below:

1. Measurement equipment: CS2000A or similar equipment.
2. DCI-P3 & Adobe color data:

CIE1976	R	G	B
DCI-P3	(0.496,0.526)	(0.099,0.578)	(0.175,0.158)
Adobe	(0.451,0.523)	(0.076,0.576)	(0.175,0.158)

3. The color gamut is calculated by using following formula: Color Gamut

$$\% = S \text{ coverage} / S \text{ original color gamut}$$

S coverage: The area covered by panel color gamut

S original color gamut: The triangle area of Adobe or DCI-P3 color gamut

For example:

$$\text{Color Gamut \%} = S_{DEB} / S_{ABC} \%$$

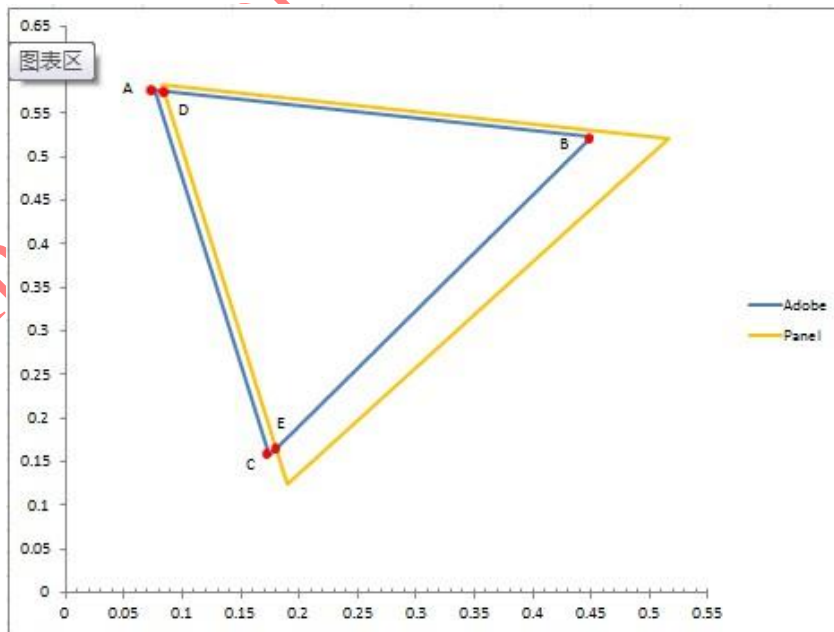

Note 5: Gamma

For gamma curve control, LTS' request as below:

1. Calibration the test instrument. Set the screen size parameters and measure the center point.
2. LTS will test the gray scale below, if possible, also can use the patterns of gray 0 to 255 to test:
for example:

0, 8, 16, 25, 33, 41, 49, 58, 66, 74, 82, 90, 99, 107, 115, 123, 132, 140, 148, 156, 165, 173, 181, 189,
197,206, 214, 222, 230, 239, 247, 255

Or 0, 1, 2, 3, ..., 252, 253, 254,255. Total 256pcs patterns.

3. Output the measure data. Data number normalization and draw the chart.

4. The whole screen should be complied with the gamma curve of gamma 2.0 or 2.4, it means +/-0.2 error is allowed.

But if there are special requirements for the special project, its required specifications can be used as a standard value, please refer the project spec.

Note 6: Response Time

Response time=Pixel turn on and turn off time (White<=>Black). It is measuring transition time from 10% to 90% of luminance.

Note 7: The definition of Viewing Angle

Refer to the graph below marked by θ and ϕ

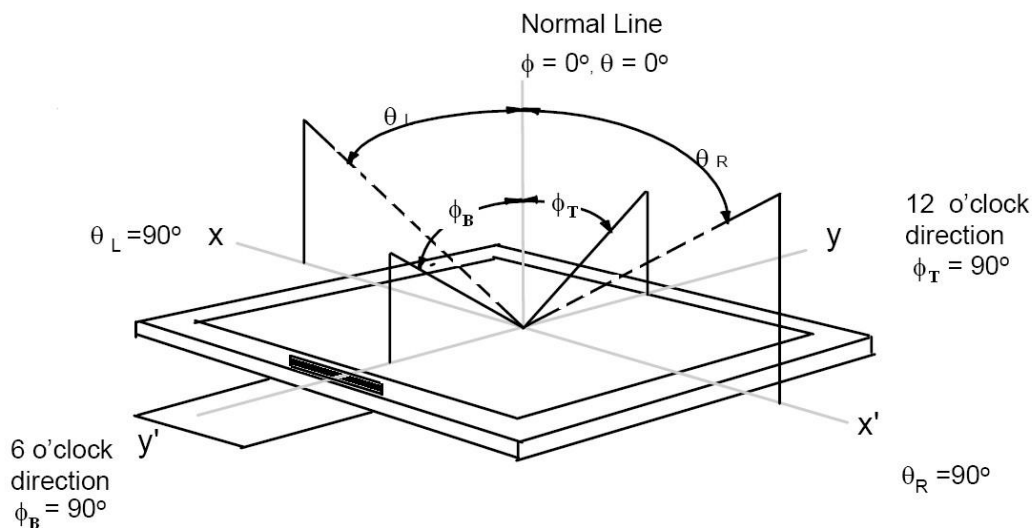

Note 8: Color Shift

For color shift measure:

Fix on white pattern,

On the condition $\theta=0^\circ$ $F=0^\circ$, we can get the color coordinate (u_1', v_1') and on $\theta=45^\circ$ $F=45^\circ$ we can get another color coordinate (u_2', v_2')

$$\Delta = \sqrt{(u_2' - u_1')^2 + (v_2' - v_1')^2}$$

JNCD stands for "Just Noticeable Color Difference" For the (u', v')

color space 1 JNCD=0.0040

4.5 JNCD means $\Delta u'v' < 0.0180$.

Note 9: White Color Coordination Tolerance

The test condition is at 25°C and measured on the surface of Display panel module.

Measurement equipment: CS2000 or similar equipment.

Measured value at the center point of Display panel at 0 hour (L_0, a_0, b_0) and t hours (L_t, a_t, b_t) , where t is an integer multiple of 240.

The index is calculated by using following formula:

$$dE = \sqrt[3]{(L_t - L_0)^2 + (a_t - a_0)^2 + (b_t - b_0)^2}$$

or

$$dL = \frac{|L_t - L_0|}{L_0}$$

The test results are in the specification.

Note10: Crosstalk

For crosstalk measure, LTS' request as below:

1. Pattern A and B are of 127 gray, the only difference is that black patch in the middle of pattern B.

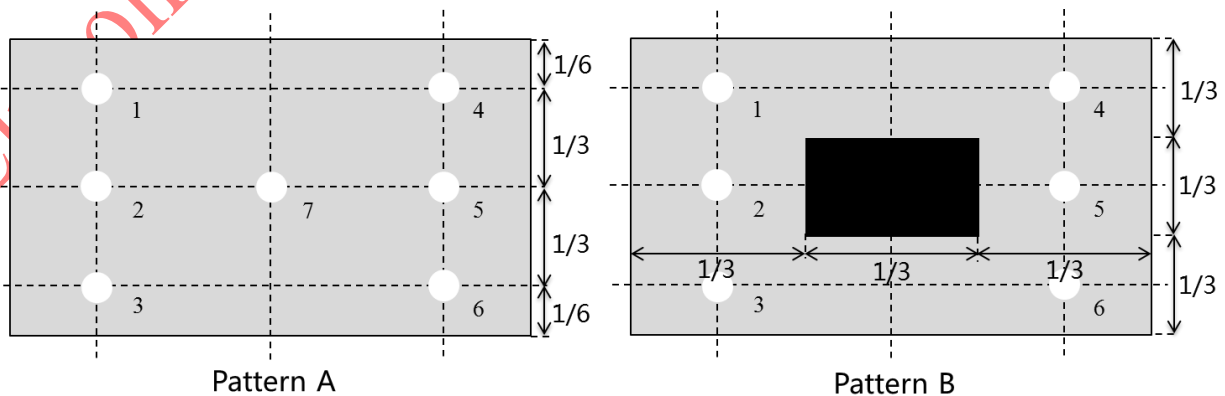

2. Calibrate the test instrument.
3. Point 7 in pattern A is used as brightness calibration for each panel. Then measure the brightness of points 1 to 6 in pattern A and B.
4. Calculate the value of crosstalk according to the formula:

$$\text{Crosstalk} = \max\left\{\frac{(B_2-A_2)-[(B_1-A_1)+(B_3-A_3)]/2}{A_2}; \frac{(B_5-A_5)-[(B_4-A_4)+(B_6-A_6)]/2}{A_5}\right\}.$$

Note 11: TUV blue ray certification

Under full white mode, test the spectra of center point, and then calculate the intensity in the range 415nm - 455nm and 400nm - 500nm. The ratio of intensity from 415nm - 455nm compared to 400nm - 500nm should be less than 50%.

Note 12: OLED Lifetime

The test procedure is as follows:

At room temperature (25°C), light the module with typical value brightness (Full white). After that, record the brightness of center point every 24 hours. Then test 600 hours or more to collect the raw data. Finally, use the raw data and the specific formulas to calculate and estimate the T50.

8. I/O connection & Block Diagram

a) I/O Connection

Connector Type: IPEX 20849-040E-01

Pin #	Signal Name	Signal Description	Pin #	Signal Name	Signal Description
1	NC	Do not used. Test pin for display.	21	BIST_EN	BIST enable signal
2	H_GND	High Speed Ground	22	VCC_3.3V	Logic and driver power
3	Lane3_N	Complement Signal Link Lane3	23	VCC_3.3V	Logic and driver power
4	Lane3_P	True Signal Link Lane3	24	VCC_3.3V	Logic and driver power
5	H_GND	High Speed Ground	25	HPD	HPD signal
6	Lane2_N	Complement Signal Link Lane2	26	EN_GND	Ground for EL PMIC
7	Lane2_P	True Signal Link Lane2	27	EN_GND	Ground for EL PMIC
8	H_GND	High Speed Ground	28	NC	NC
9	Lane1_N	Complement Signal Link Lane1	29	VBAT	Power for EL PMIC

10	Lane1_P	True Signal Link Lane1	30	VBAT	Power for EL PMIC
11	H_GND	High Speed Ground	31	VBAT	Power for EL PMIC
12	Lane0_N	Complement Signal Link Lane0	32	NC	Do not used. Test pin for display
13	Lane0_P	True Signal Link Lane0	33	NC	Do not used. Test pin for display
14	H_GND	High Speed Ground	34	NC	Do not used. Test pin for display
15	Aux_CH_P	True signal Aux channel	35	NC	Do not used. Test pin for display
16	Aux_CH_N	Complement signal Aux channel	36	NC	Do not used. Test pin for display
17	H_GND	High Speed Ground	37	NC	Do not used. Test pin for display
18	Logic_GND	Logic and driver ground	38	NC	Do not used. Test pin for display
19	Logic_GND	Logic and driver ground	39	NC	Do not used. Test pin for display
20	Logic_GND	Logic and driver ground	40	NC	Do not used. Test pin for display

b) Display Module Block Diagram

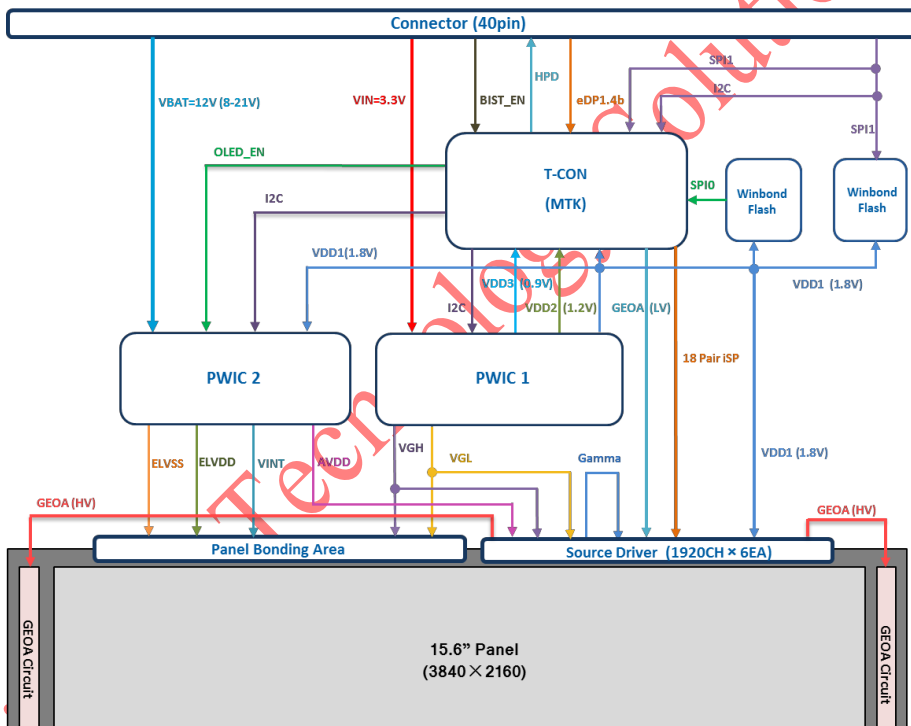

9. Recommended Operating Sequence

TBD

10. Interface

Resolution	3840(H) × 2160(V)	
eDP Speed	Typ	5.4 Gbps
Frame Freq.	Typ	60 Hz
Porch	HFP + HBP (with HS)	560
	VFP + VBP (with VS)	48

11. Reliability

Item		Condition	Time/Cycle	QTY
High Temperature Operation		70°C	240hrs	5pcs
Low Temperature Operation		-20°C	240hrs	5pcs
High Temperature Storage		85°C	240hrs	5pcs
Low Temperature Storage		-40°C	240hrs	5pcs
High Temperature Humidity Operation		60°C/93%	240hrs	5pcs
Thermal Shock		-40°C/85°C Dwell time=0.5h	100cycles	5pcs
ESD	Non-Operating	Contact +/- 9kV, 150pF, 330Ω, Front 5point	once/point	3pcs
		Air +/- 10kV, 150pF, 330Ω, Front 5point	once/point	3pcs
Vibration test	Non-Operating	1.5Grma 10~500Hz Random X Y Z 1H		1Carton
Packing Drop test	Non-Operating	60cm height, 6-faces, 3-edges and 1-corner (one time for each)		1Carton

12. Handling Precautions

- When cleaning ITO pad, avoid using hard and abrasive material or corrosive solution.
- Keep module away from direct sunlight or fluorescent light and keep it at room temperature and humidity.
- Strong impact & pressure on module and packing is prohibited.
- Following normal power on/off sequence is necessary for preventing abnormal display or permanent damage to display.

- e) Optimal contrast ratio under ideal voltage is AMOLED module's characteristic, hence it is recommended a voltage control function available.
- f) Image sticking may occur if an image displays for an extended period of time.
- g) When interfered by system's overall mechanical design, an abnormal display may occur.
- h) After considering emitting energy, you should plan your design to satisfy EMI standards.
- i) Host side should place a surge-prevent circuit at power trace (ie: VCI, Vddi) to protect AMOLED module.

13. Outline Dimension Drawing

Confidential

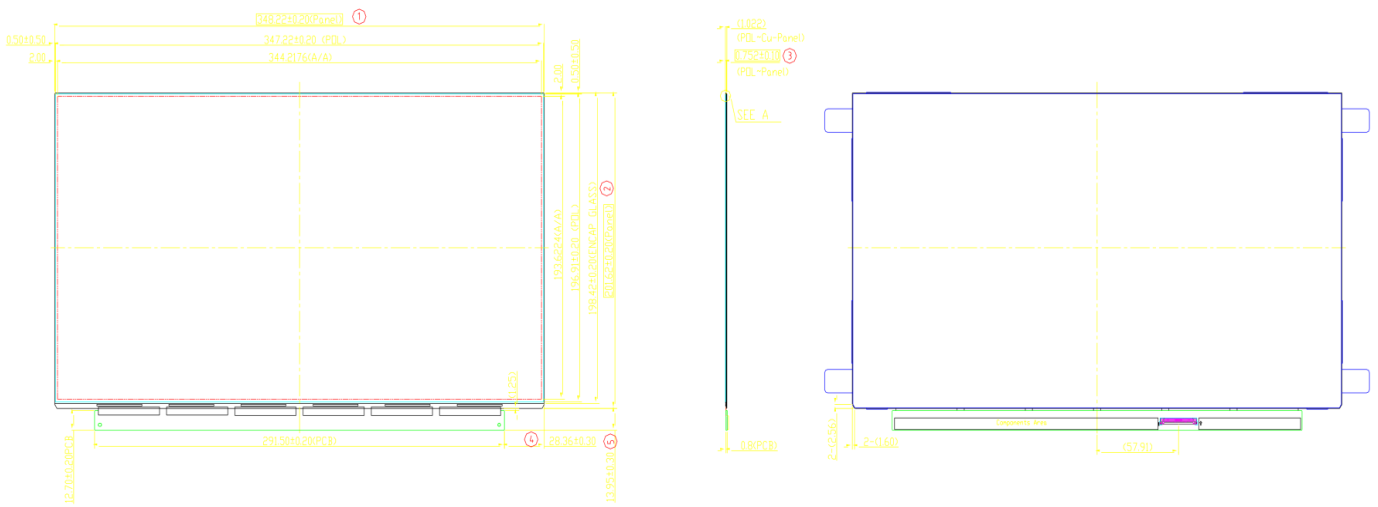

14. Packing Specification

TBD

15. The Control of Hazardous substances

The Control of Hazardous substances refer to LTS document. (Standard document for the Control of Hazardous substances.)

Lincoln Technology Solutions Confidential