

# TACHAMMER™

Haptic actuator with Linear Magnetic Ram (LMR) technology. Features traditional and impact haptic generation

---

High-fidelity simulation of real world haptics

---

27 G peak acceleration

---

High operating efficiency: <math>2 \mu\text{A}</math> / click

---

Operating voltage: 3.6 - 10 Vp-p

---

Operating frequency: Impact: 0.5 - 155 Hz / Traditional: 0.5 - 200Hz

---

Compatible with standard haptic drive electronics

---

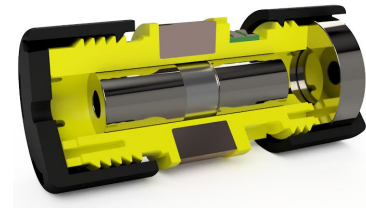

## TACHAMMER

LMR CLASS HAPTIC ACTUATOR

### 3 HAPTIC MODES:

IMPACT | VIBRATION | PULSE

Product ID: C-151L337V5R2  
Revised February 12, 2019

# TACHAMMER

## LMR CLASS HAPTIC ACTUATOR

---

<b>1 Getting Started</b>	<b>3</b>
1.1 Operating Principles	3
<b>2 Specifications</b>	<b>4</b>
2.1 Performance Specifications (ES1)	4
2.2 TacHammer™ Frequency Response	5
2.3 Recommended Operating Conditions	6
2.4 Electrical Characteristics	6
2.5 Mechanical Characteristics	6
2.6 Mounting Boss Specification	7
2.7 Product Dimension Specification	8
<b>3 Impact Tuning</b>	<b>9</b>
3.1 Impact Materials	9
3.1.1 Soft Materials Overview	9
3.1.2 Hard Materials Overview	9
3.2 Acceleration and SPL Effect of Soft Impact Materials	10
<b>4 Application Notes</b>	<b>11</b>
4.1 Driving Signal	11
4.1.1 Single Haptics	11
4.1.2 Repeated Haptics	11
4.2 Response Time Note	12
4.3 Driving Note	12
4.4 Measurement Method	12
4.4.1 Test Equipment	12
4.4.2 Test Fixture Setup	13
4.4.3 Waveform Interpretation	14
<b>5 Standard Test Conditions</b>	<b>15</b>
5.1 Test Environment	15
5.2 Reliability Tests and Criteria	15

Product ID: C-151L337V5R2

Revised February 12, 2019

# 1 Getting Started

## 1.1 Operating Principles

The TacHammer™ haptic actuator provides two different haptic sensations based on the actuation direction of the ram.

A “**hit**” is an impact haptic produced when striking the ram on a mechanical feature. This feature may be internal or external to the component (ie part a housing). Hits may produce audible effects which can be tuned through variations in the struck material.

A “**pulse**” is a non-impact haptic effect produced by driving the ram towards a magnetic brake within the component. Pulses are silent and do not produce audible effects. The haptics generated in this mode are similar to ERM & LRA effects.

Direction of Impact Mode Operation

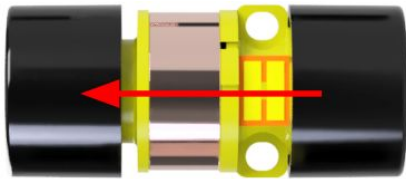

Direction of Traditional Mode Operation

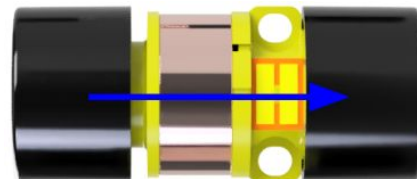

Both hits and pulses have variable intensities and actuation durations. Hits are used to generate sharp, momentary g-forces (like a click), and pulses are typically used to generate force sensations (like a bump).

Hits and pulses may be used in combination. A typical alert vibration for example is created through a chain of pulses actuated at a specified frequency. Combinations of hits and pulses provide for a range of new effects, like the snap of a latch, or the creaking of a door.

## 2 Specifications

### 2.1 Performance Specifications (ES1-2)

PARAMETER	IMPACT HAPTIC MODE			TRADITIONAL HAPTIC MODE			UNIT
	MIN	TYP.	MAX	MIN	TYP.	MAX	
Peak Acceleration		27.0			11.1		G
Peak Acceleration Frequency (Resonance) <sup>1</sup>		45			70		Hz
RMS Acceleration at Peak Acceleration Frequency <sup>2</sup>							Grms
RMS Current at Peak Acceleration Frequency <sup>2</sup>		52			59		mA
RMS Power at Peak Acceleration Frequency <sup>2,3</sup>		20.6			26.1		mW
Acceleration Efficiency <sup>2</sup>		1314			190		G/W
Click Energy <sup>4</sup>		0.3			0.2		μAh
Latency <sup>5</sup>		7.5			0		ms
Rise Time <sup>5</sup>		0.2			5.1		ms
Fall Time <sup>5</sup>		6.3			7.5		ms
Noise at Peak Acceleration Frequency <sup>6</sup>							dbA
Operating Life <sup>7</sup>			10 million			10 million	cycles

#### Notes:

1. Resonance defined as the frequency that yields the highest peak acceleration at 10 Vp-p
2. Measured at 10 Vp-p, 100g jig, at peak acceleration frequency. mass driven towards accelerometer
3. Power calculated as  $P = I_{rms}^2 \cdot Resistance$
4. Click Energy defined as the energy to perform a single click.  
 Calculated as  $ClickEnergy = \frac{I_{instantaneous} \cdot PulseWidth}{3600}$
5. See section 4.2 *Response Time Note* for additional details  
 Impact measured at: 5V, 100g jig, 1Hz, 7.8ms pulse width  
 Traditional measured at: 5V, 100g jig, 1Hz, 7.8ms pulse width
6. Measured from 10cm
7. 1 Cycle is defined as one complete movement of the actuator from rest to rest. Tested at 10 Vp-p, 30Hz@30% duty cycle

## 2.2 TacHammer™ Frequency Response

TacHammer Performance (Impact Mode)

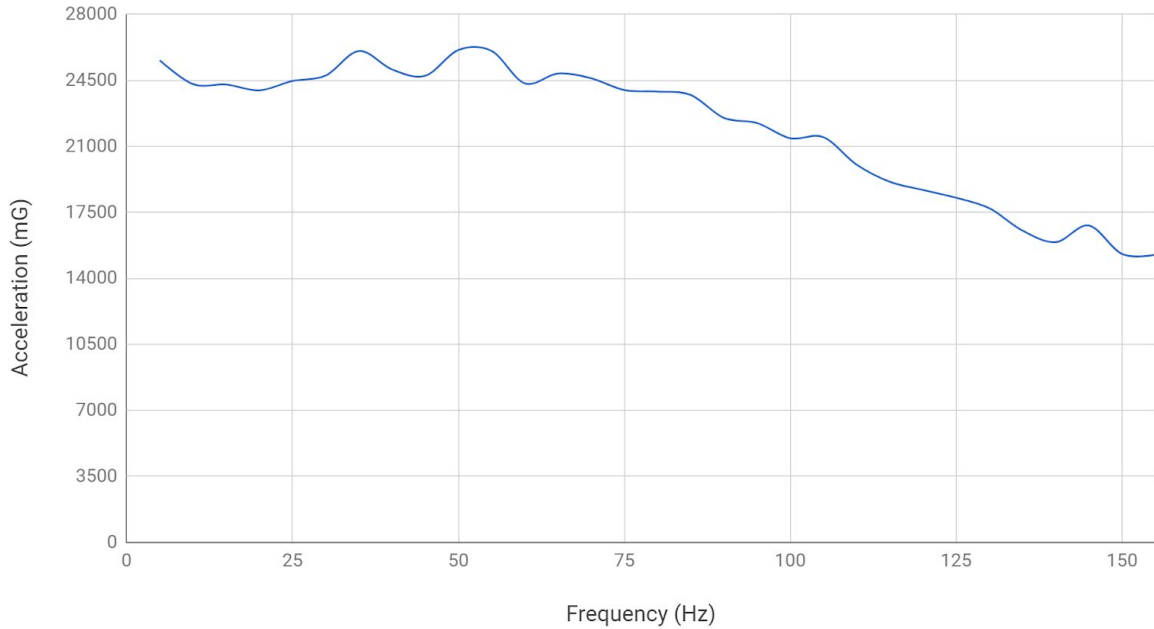

TacHammer Performance (Traditional Mode)

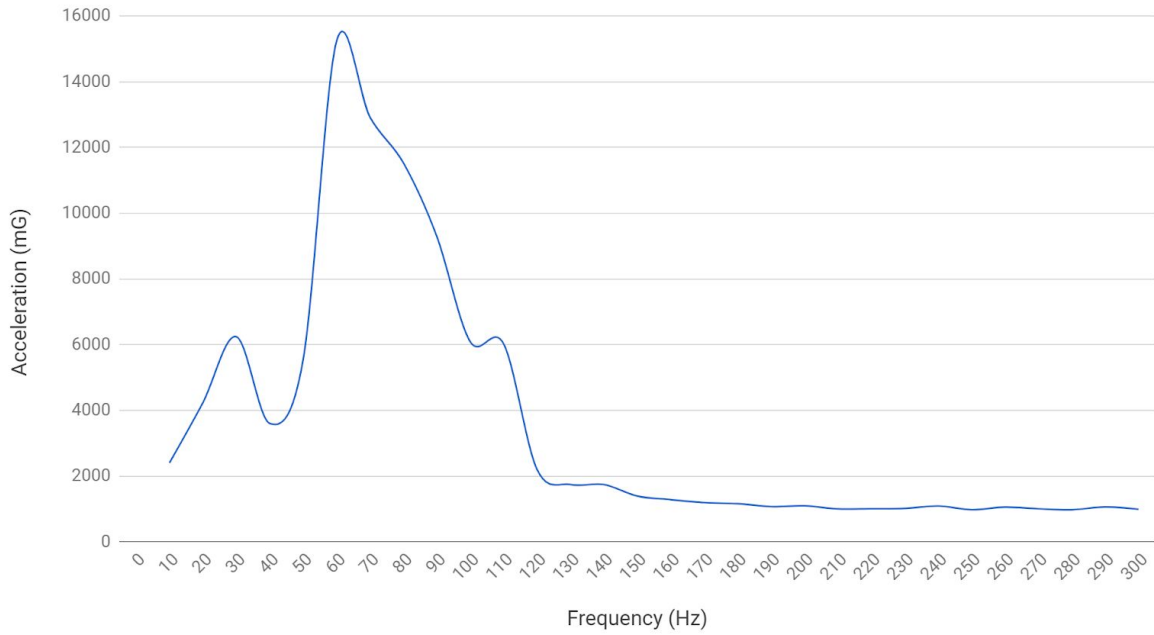

## 2.3 Recommended Operating Conditions

PARAMETER	MIN	MAX	UNIT
Operating Voltage	3.6	10	Vp-p
Drive Frequency (Impact)	0.5	155	Hz
Drive Frequency (Non-Impact)	0.5	200	Hz
Operating Temperature	-20	60	°C

## 2.4 Electrical Characteristics

PARAMETER	MIN	TYP	MAX	UNIT
Coil Resistance @ 20°C		7.5		Ω
Inductance @ 100 Khz, 0.1V				mH

## 2.5 Mechanical Characteristics

PARAMETER	SPECIFICATION
Dimensions	15 mm x 15 mm x 34.3 mm
Total Weight	15 g
Connector Type	Flying Lead

## 2.6 Mounting Boss Specification

SCREW DIMENSIONS		
DIMENSION	SYMBOL	VALUE (mm)
Recess Width	A	1.75
Nominal Screw Diameter	d1	2
Screw Head Diameter	d2	3.5
Screw Height	k	1.6
Thread Length	L	6
Recess Depth	t	7

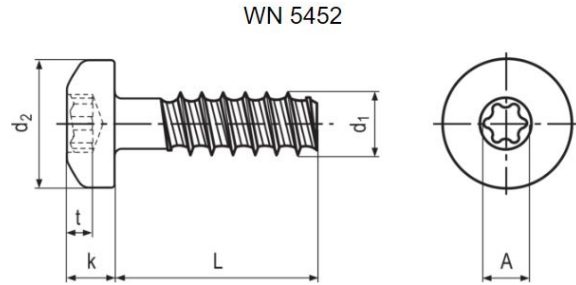

BOSS DIMENSIONS		
DIMENSION	SYMBOL	VALUE (mm)
Nominal Screw Diameter	d1	2
Boss Diameter	D	4
Edge Relief	de	2.2
Edge Relief Height	he	0.6-0.8
Thread Engagement	te	4
Pilot Hole	d	1.6
Recommended minimum 1° draft		

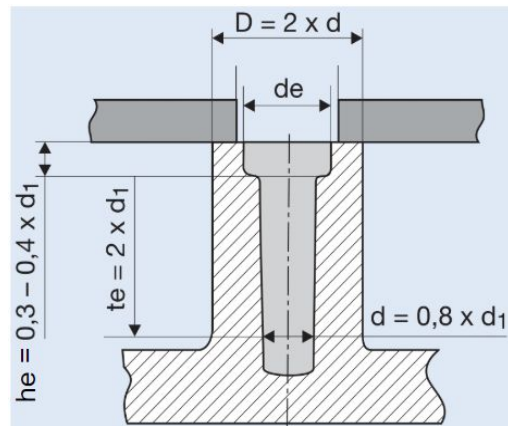

### SCREW MOUNT DIMENSIONS

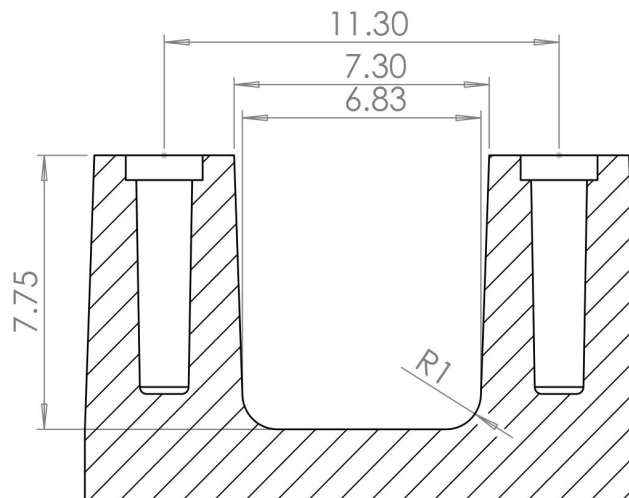

## 2.7 Product Dimension Specification

\*All dimensions in mm

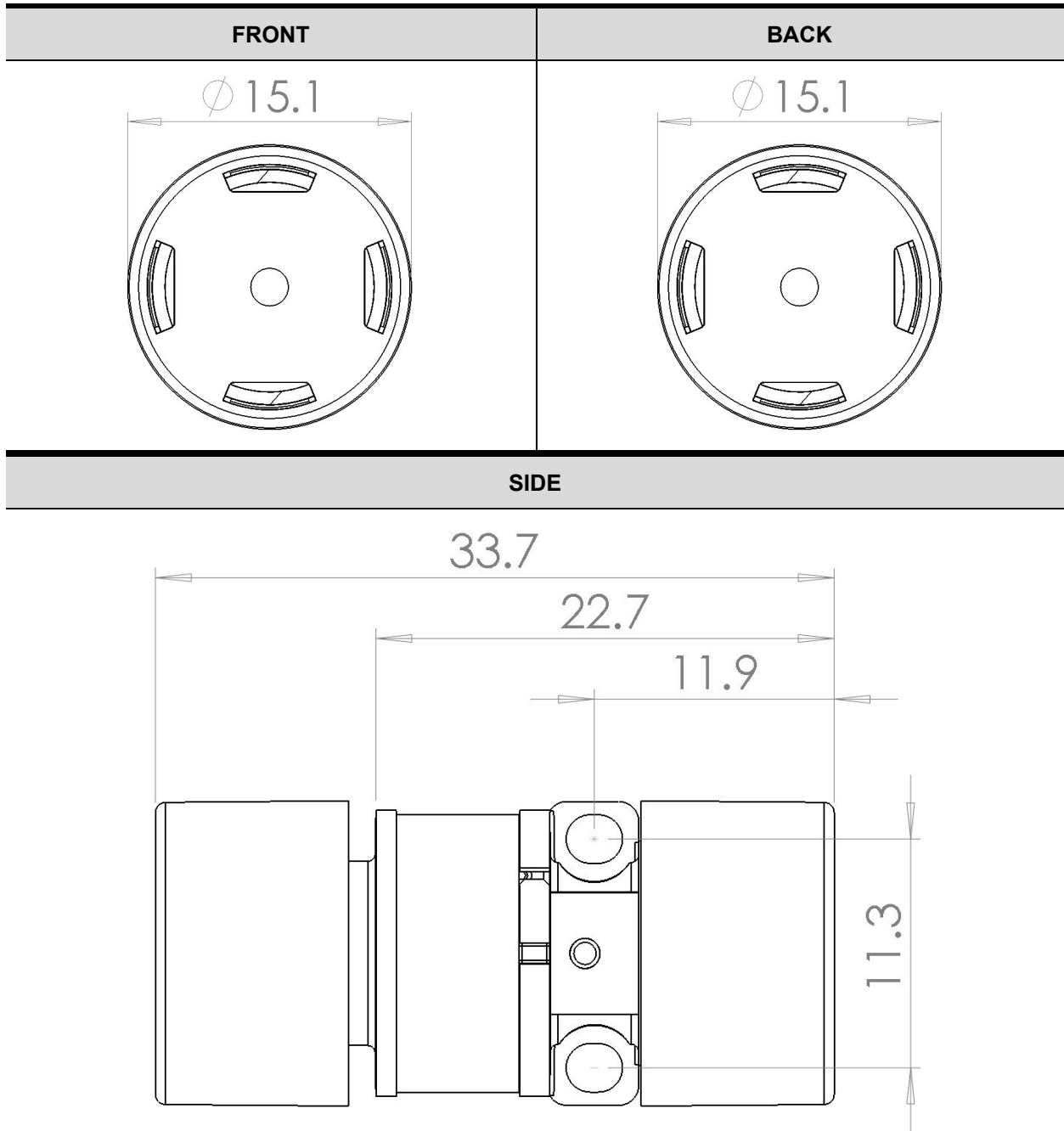



### 3 Impact Tuning

Discs can be installed in the TacHammer unit to modify and tune the haptic quality of the impact mode haptics. It should be noted that the following listed materials are a suggested starting point and not a comprehensive list of materials compatible with the TacHammer. The sections below will detail the materials included as well as offer suggestions on how to use them.

#### 3.1 Impact Materials

##### 3.1.1 Soft Materials Overview

These materials soften the blow of the impact, primarily reducing the sound created when generating haptics and changing the quality of the haptic to be heavier and less sharp. Suggested materials to be used include:

MATERIAL	COLOR	THICKNESS (MM)
Poron 1/32"	Black	0.8
Poron 1/16"	Black	1.6
Silicon 10A	Red	1.6
Silicon 20A	Red	0.8

##### 3.1.2 Hard Materials Overview

These materials enhance and sharpen the quality of the haptic on impact. Suggested materials to be used include:

MATERIAL	COLOR	THICKNESS (MM)
Aluminum	Silver	1
Copper	Copper	1
Acrylic	Clear	1
Delrin	Black	1
Phosphor Bronze - 0.1mm	Bronze	0.1
Phosphor Bronze - 0.2mm	Bronze	0.2

### 3.2 Acceleration and SPL Effect of Soft Impact Materials

#### Acceleration % Difference

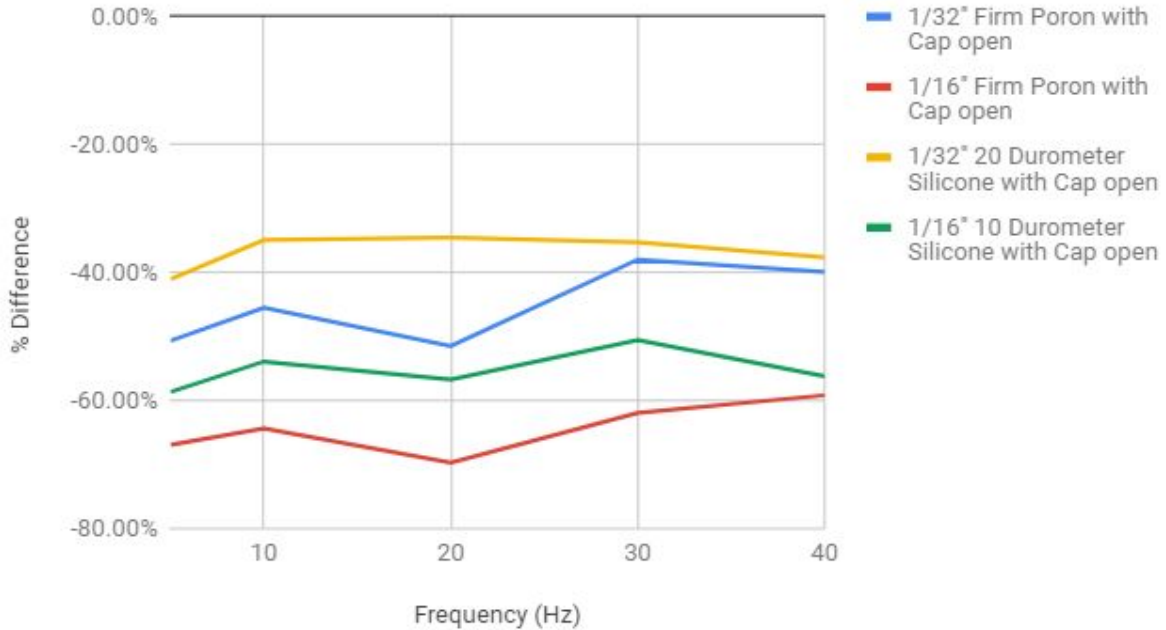

#### SPL (dbA) % Difference

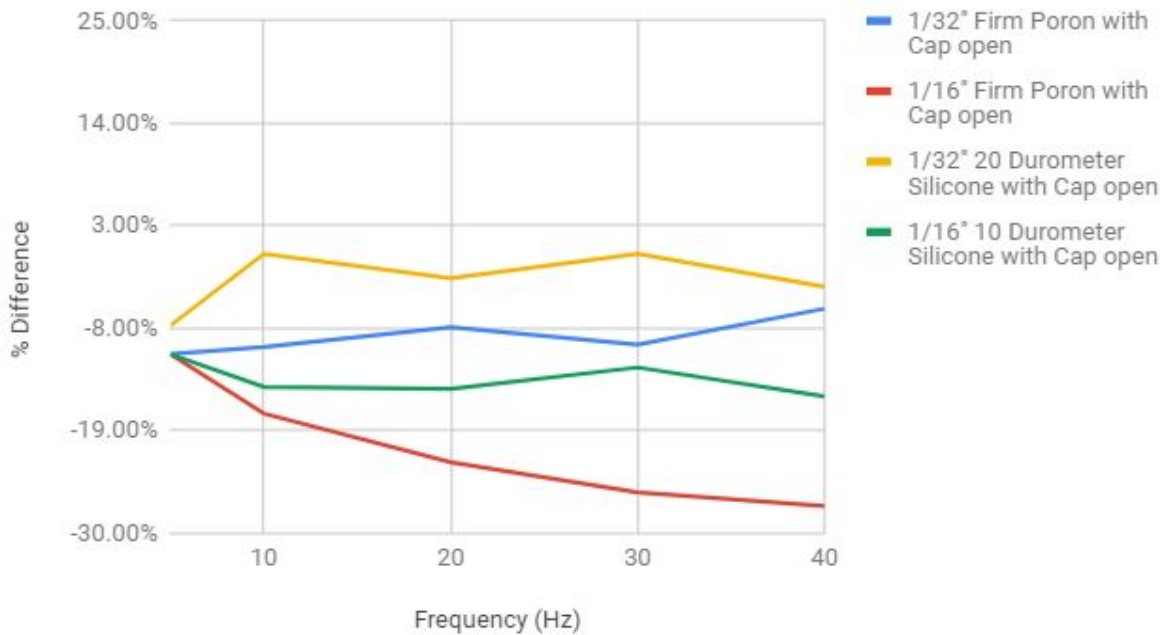

## 4 Application Notes

### 4.1 Driving Signal

#### 4.1.1 Single Haptics

Single haptics such as a single Hit or Pulse is optimally driven with a single pulse. The following table lists the recommended duration for the respective haptic.



HAPTIC	DURATION	UNIT
Hit	8.6	ms
Pulse	5.2	ms

#### 4.1.2 Repeated Haptics

For repeated haptics such as vibrations, the TacHammer™ haptic actuator is optimally driven with a square wave input. The following tables list recommended frequencies and duty cycles.

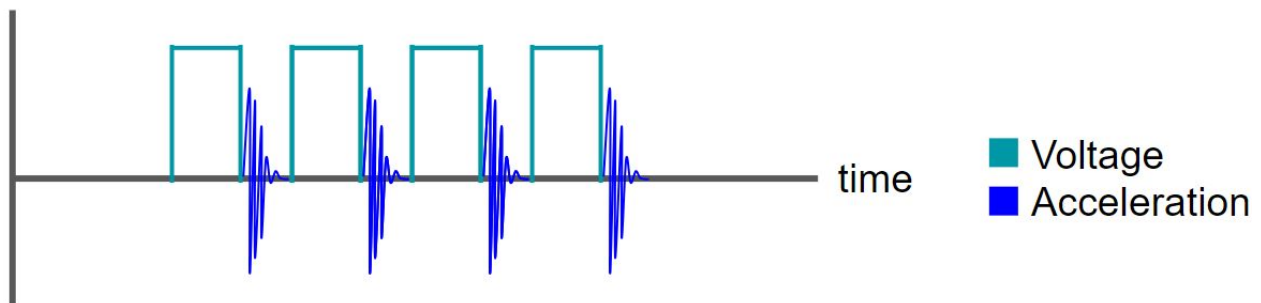

## 4.2 Response Time Note

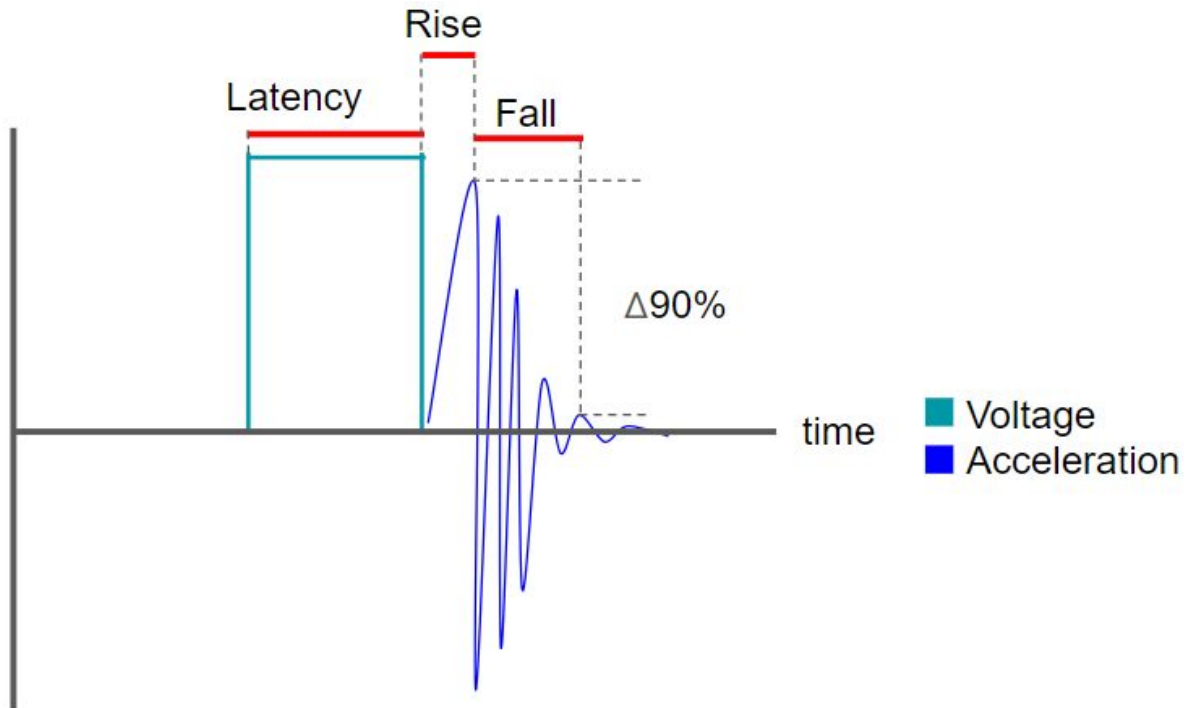

Note: Above image is a representation of the driving signal and corresponding acceleration waveform for a single impact haptic.

## 4.3 Driving Note

This device may be driven using off the shelf haptic driver ICs such as the TI DRV2605 in PWM mode or by a simple H-Bridge.

Additionally, the device is fully back compatible and is capable of taking advantage of LRA waveforms and libraries, such as that found on the TI DRV2605.

## 4.4 Measurement Method

### 4.4.1 Test Equipment

FUNCTION	MANUFACTURER	MODEL NUMBER
Accelerometer	Dytran	723A3
Power Supply	Agilent	6632B
Signal Generator	Rigol	DG1022
Signal Amplifier	Rigol	PA1011
Oscilloscope	Lecroy	Waverunner 204MXI

4.4.2 Test Fixture Setup

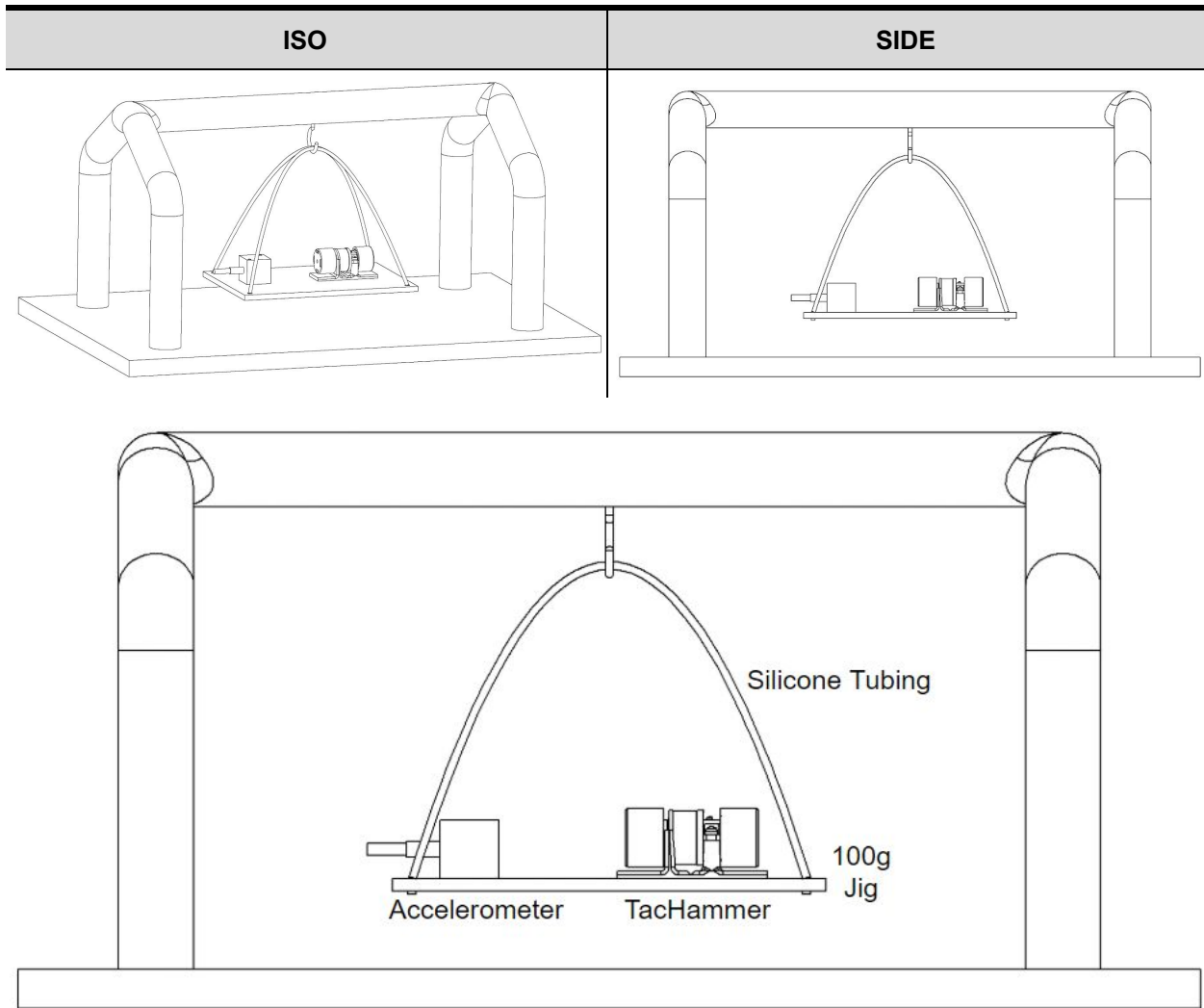

The TacHammer unit is firmly mounted with the use of a fixture to the 100g jig. An accelerometer is also firmly mounted along the axis of the TacHammer. The entire structure is suspended from a singular point in the surrounding structure with soft silicone tubing. This method of mounting allows the entire 100g assembly to experience acceleration with 6 DOF.

### 4.4.3 Waveform Interpretation

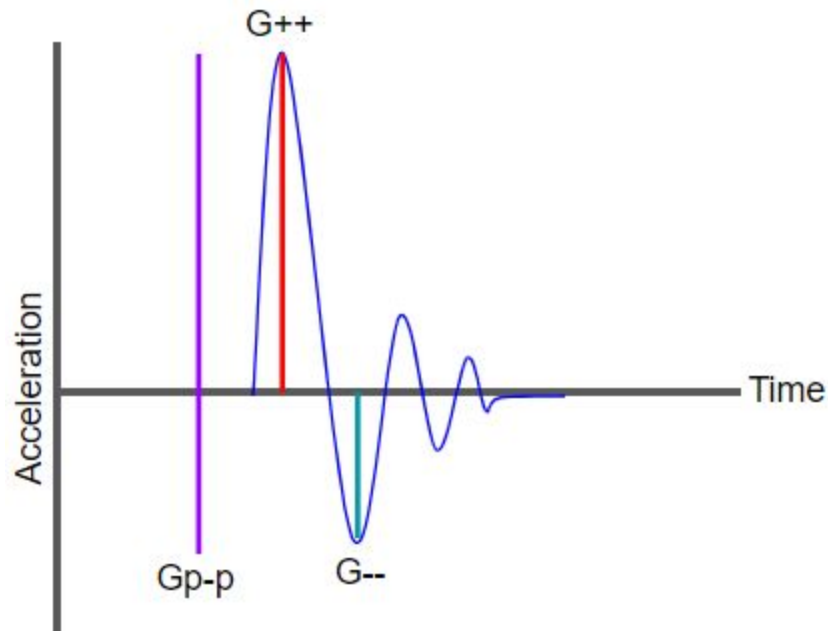

Acceleration values are computed by taking the resultant of the maximum absolute values of the acceleration in all three axes. In the case above, the G++ value would be taken. Assuming the waveform is similar in the X, Y, Z axes, the calculation for the acceleration is as follows:

$$Acceleration = \sqrt{G_x^2 + G_y^2 + G_z^2}$$

## 5 Standard Test Conditions

### 5.1 Test Environment

- The standard measurement environment is  $25^{\circ}\text{C} \pm 3^{\circ}\text{C}$  &  $65\% \text{ RH} \pm 20\% \text{ RH}$  unless otherwise marked
- All temperatures  $< 0^{\circ}\text{C}$  are  $+0^{\circ}\text{C}/-3^{\circ}\text{C}$  standard unless otherwise marked
- All temperatures  $> 0^{\circ}\text{C}$  are  $+3^{\circ}\text{C}/-0^{\circ}\text{C}$  standard unless otherwise marked
- All tests to be performed in Impact mode unless otherwise marked
- All duty cycles are better than  $\pm 0.05\%$  unless otherwise marked
- All frequencies are better than  $\pm 200 \text{ ppm}$  (or  $0.02\%$ ) unless otherwise marked

### 5.2 Reliability Tests and Criteria

This section contains a detailed list of tests and success criteria

TEST NAME	TEST DESCRIPTION	TEST STANDARD	SUCCESS CRITERIA
Drop Test	Drop JIG : 180g including the Actuator and assembly screws. Drop from 1.0m in specified drop buck onto 6 face. Actuator is not powered.		Performance specifications within 20% of original ( after 4hours of recovery after test )
Life Test - Impact	$25^{\circ}\text{C}/50\%\text{RH}$ . The life test cycle, 1s on, 1s off, 200 Hours		Performance specifications within 20% of original ( after 4hours of recovery after test )
Life Test - Non-Impact	$25^{\circ}\text{C}/50\%\text{RH}$ . The life test cycle, 1s on, 1s off,silent mode, 200 Hours		Performance specifications within 20% of original ( after 4hours of recovery after test )
High Temperature Storage	$80^{\circ}\text{C}$ , 96 hours. Actuator is not powered.	EIA-364-17	Performance specifications within 20% of original ( after 4hours of recovery after test )
Low Temperature Storage	$-40^{\circ}\text{C}$ , 96 hours. Actuator is not powered.	EIA-364-17	Performance specifications within 20% of original ( after 4hours of recovery after test )
High Temperature and Humidity Life Test	$60^{\circ}\text{C}/95\%$ . The life test cycle, 1s on, 1s off, 40 Hours.	EIA-364-17	Performance specifications within 20% of original ( after 4hours of recovery after test )
Low Temperature Life Test	$-20^{\circ}\text{C}$ . The life test cycle, 1s on, 1s off, 72 Hours.	EIA-364-17	Performance specifications within 20% of original ( after 4hours of recovery after test )
Long Life Test	$25^{\circ}\text{C}/50\%\text{RH}$ . The life test cycle, 1s on, 1s off, 600 Hours		Performance specifications within 20% of original ( after 4hours of recovery after test )
Thermal Shock Test	5 cycles of $-20^{\circ}\text{C}$ for 30 minutes then $+70^{\circ}\text{C}$ for 30 minutes. The life test cycle, 1s on, 1s off, 5 temperature cycles.	EIA-364-32	Performance specifications within 20% of original ( after 4hours of recovery after test )

Salt Spray Test	35°C and 5% salt solution concentration. The life test cycle, 1s on, 1s off, 8 Hours.	EIA-364-26	Performance specifications within 20% of original ( after 4hours of recovery after test )
Non-Operating Random Vibration Test	JIG:180g including the Actuator and assembly screws. 3 axes, 10 minutes per axis, 6 g, 10-2000Hz. Actuator is not powered.	EIA -364-28	Performance specifications within 20% of original ( after 4hours of recovery after test )
Shock Test	JIG: 180g including the Actuator and assembly screws. Half sine shock plus,+X/-X/+Y/-Y/+Z/-Z axis,each axis 3 times,500G,Actuator is not powered.	EIA -364-27B	Performance specifications within 20% of original ( after 4hours of recovery after test )
Solderability Test	Subject connector to the solder pot Temperature:245±5°C.3~5 sec.	EIA-364-52	Performance specifications within 20%of original ( after 4hours of recovery after test )