

Series 40-5 Wedge-Lok

CONNECT AND PROTECT



RECOMMENDED GAP WIDTH

PCB + 7.62 (.300)

RECOMMENDED TORQUE

80 N-cm (7 in-lbs)

WEIGHT

1.16 g/cm (.104 oz/in)

MATERIALS AND FINISH

WEDGES

- **Material:** Aluminum Alloy 6061-T6 per QQ-A-200/8
- **Finish:** See finish table on opposite page

SCREW

.09-in. or 2.5-mm hex. socket head cap screw, depending on mounting configuration

- **Material:** 300 series stainless steel per QQ-S-763 ASTM A-582 A286 per FF-S-86 with dry film lube per MIL-L-46010 for "TLC" option
- **Finish:** Passivated per AMS2700

ALIGNMENT SPRINGS

- **Material:** 301 stainless steel half hard per AMS 5518
- **Finish:** Passivated per AMS2700

OPTIONAL LOCK AND FLAT WASHER

- **Material:** 300 series stainless steel per QQ-S-763 and ASTM A-582
- **Finish:** Passivated per AMS2700

OPTIONAL LOCK AND FLAT WASHER

- **Material:** Type A286 stainless steel per ASTM AMS 5525
- **Finish:** Silver plate per AMS 2410

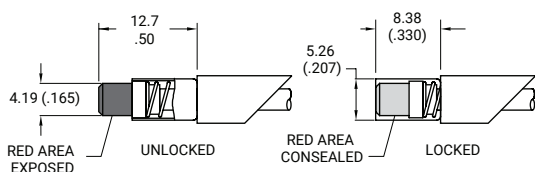
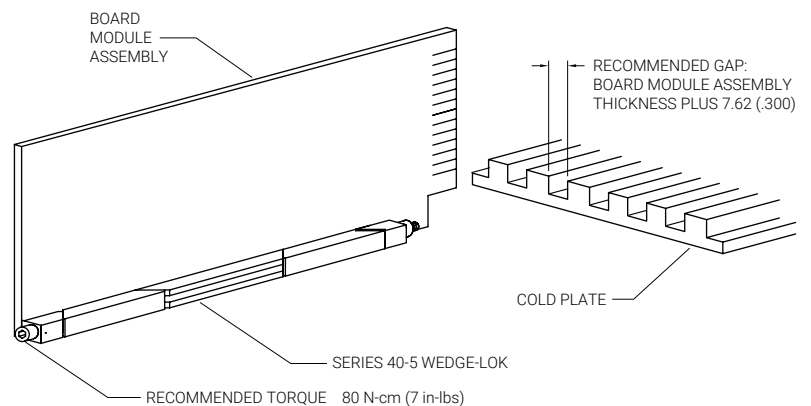
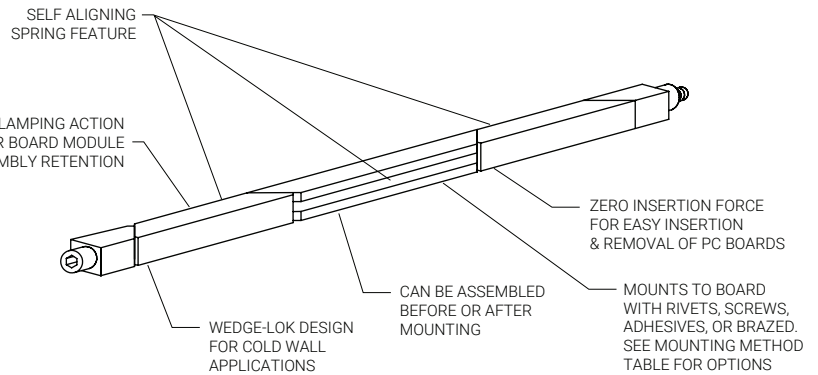

VI OPTION

Indicates assembly is unlocked (adds 5.1 (.20) to screw length)

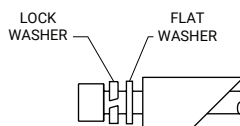

LF OPTION

Provides additional resistance to shock and vibration (adds 2.5 (.10) in screw length)

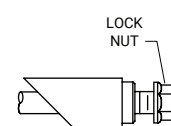

LN OPTION

Captivates rear wedge when untorqued (adds 2.5 (.10) to screw length)

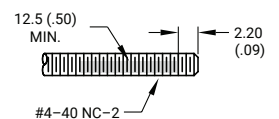

LO OPTION

Provides additional resistance to shock and vibration

SERIES 40-5 WEDGE-LOK

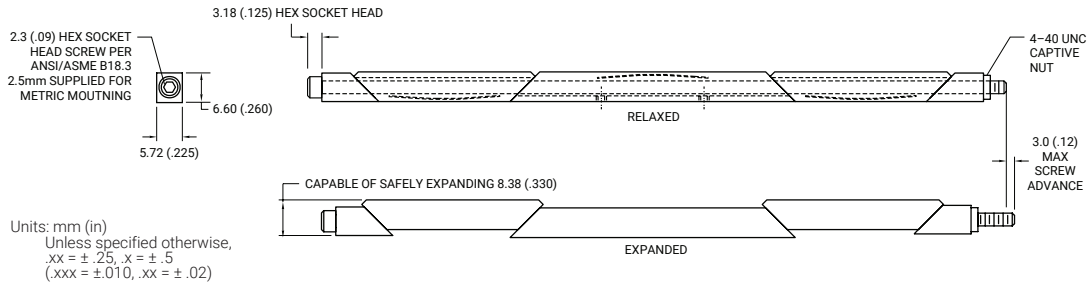

MOUNTING HOLE LOCATION

22.86 (.900) hole spacing centered on mounting body
-10 thru -13 2 holes
-14 thru -24 4 holes

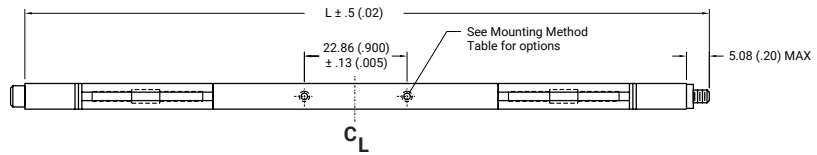

Part Number Code	40-5 VI - 10 - B - LF - LN - T - L
Type	Torque Limiting Version* TLC Standard version with Visual Indicator VI Standard version [Blank]
Length	Length in 12.7 (.50) increments 10 [127.0 (5.00)] to 24 [304.8 (12.00)]
Finish	Black Anodized B or select code letter from Finish Table
Lock/Flat Washers and Locknut	Lock Washer and Flat Washer LF None [Blank]
Lock Nut	Lock Nut LN None [Blank]
Mounting	Standard 2-56 UNC-2B Tapped Holes [Blank] Or select code letter from Mounting Method Table
Lock Patch	Lock Patch L None [Blank]

FINISH TABLE

DASH #	SURFACE FINISH
[Blank]	CHEMICAL FILM PER MIL-DTL-5541, TYPE I, CLASS 1A, GOLD, NON ROHS COMPLIANT
CC	CHEMICAL FILM PER MIL-DTL-5541, TYPE II, CLASS 1A, CLEAR
EN	ELECTROLESS NICKEL PER MIL-C-26074, CLASS 4, GRADE B, BRIGHT
N	NICKEL PLATE PER QQ-N-290, CLASS 1, GRADE G, BRIGHT
B	BLACK ANODIZE PER MIL-A-8625, TYPE II, CLASS 2
B3	HARD BLACK ANODIZE PER MIL-A-8625, TYPE III, CLASS 2 HARD
B3D	BLACK ANODIZE WITH DRY FILM LUBE PER MIL-L-46010

MOUNTING METHOD TABLE

CODE LETTER	METHOD
[Blank]	2-56 UNC-2B TAPPED HOLE
R	RIVET MOUNT (ø 1.70 + .10/- .03 (.067 + .004/.001) THRU u ø3.96 (.156) √ 5.08 (.200) v 3.56 (.140) x 100°) RIVET "R" PARTS ARE SHIPPED UNASSEMBLED AND EXCLUDE ALIGNMENT PINS
A	NO MOUNTING HOLES
T	0-80 UNF-2B TAPPED HOLE
M2	M2 X .40 TAPPED HOLE
M	M2.5 X .45 TAPPED HOLE

NOTE: FOR TORQUE LIMITING (TLC) VERSION: VISUAL INDICATOR (VI) LOCK/FLAT WASHER (LF) , LOCK PATCH (L) OPTIONS NOT AVAILABLE ONE ALIGNMENT SPRING FOR -10 TO -15 LENGTHS MUST CLICK 3+ TIMES FOR PROPER INSTALLATION

nVent SCHROFF, Inc.

7328 Trade Street San Diego,
CA 92121 USA
+1 800-525-4682

BIRTCHER™



Our powerful portfolio of brands:

CADDY ERICO HOFFMAN RAYCHEM SCHROFF TRACER