

## RCxxxxHP-DK Development Kit User Manual

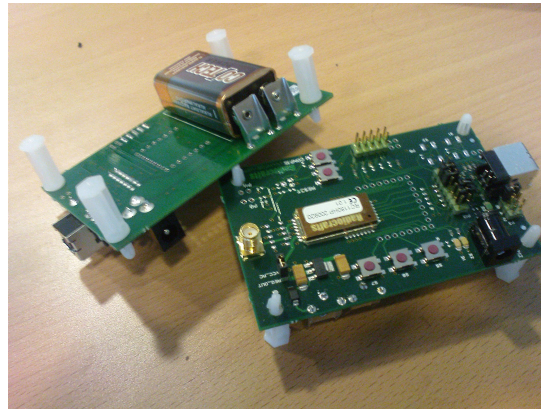

### Table of contents

QUICK START GUIDE.....	2
DEVELOPMENT KIT INTRODUCTION.....	3
DEVELOPMENT BOARD INTRODUCTION .....	4
BLOCK DIAGRAM.....	7
JUMPER SECTION.....	8
PROTOTYPING WITH THE RCXXXHP-DB.....	9
ANTENNA SELECTION VERSUS RANGE PERFORMANCE .....	10
RCXXXHP-DB CIRCUIT DIAGRAM, PCB AND ASSEMBLY LAYOUT .....	11
TROUBLESHOOTING .....	11
KNOWN ISSUES.....	12
DOCUMENT REVISION HISTORY.....	13
DISCLAIMER .....	13
TRADEMARKS .....	13
LIFE SUPPORT POLICY .....	13
CONTACT INFORMATION.....	13

## Quick Start Guide

### How do I set up a simple link between the boards?

To do a basic communication test, do like this for each of the Development Boards:

- Attach the antenna to the SMA connector
- Download the latest version of RCTools from [www.radiocrafts.com](http://www.radiocrafts.com)
- Install RCTools (this will also install the USB VCP (Virtual COM Port) driver)
- Connect the USB port to a PC
- Connect the external power supply
- Start a terminal program on the PC (RC232\_CCT or Microsoft HyperTerminal program)
- Select the correct COM-port and set data rate 19200, 1 start bit, no parity, 1 stop bit, no flow control

The module will now be in idle mode listening for a valid data packet to arrive. Now you can enter data in one terminal window and after a predefined timeout, the ASCII string is transmitted to the other module and shown in the other terminal window if the transmission was successful.

### How do I find the COM Port to use?

A list of all available COM-ports on your PC is found from the Windows Device manager. This is opened by "Start->Run" and type "devmgmt.msc". Alternatively, Open "System" from "Control Panel" and select the Hardware tab and click on the Device Manager button. In the Device Manager you can expand the "Ports (COM & LPT)" tab to get the list of both Standard COM ports and USB COM ports connected to your PC. For details please see the Installation Guide.

### How do I go on and change the RF channel or any other parameter?

To change configurable parameters, assert the CONFIG pin (pulling low by pressing CONFIG-button, see Figure 1), and send the command string using the same serial interface as for transmitting data. Parameters can be changed permanently and stored in non-volatile memory in the module. See the User Manual for the CCT software for details on how to change settings by using this tool. The details for the configuration memory contents can be found in the RC232 User Manual, the MBUS User Manual, the WIZE User Manual, the SIG User Manual or the TinyMesh™ Data Sheet respectively.

### Why is it an USB connector when the Radiocrafts modules use a serial UART?

The benefit of USB is that power is available from the Port. The RCxxxxHP-DB has an USB to UART converter from FTDI that includes a Virtual COM Port (VCP) driver that allows you to use the Development boards with any PC software that originally require a serial COM port. This means that the PC will communicate with the module using a serial connection via the virtual COM port. Both standard terminal program and the RCTools PC suite from Radiocrafts can for this reason be used together with the RCxxxxHP-DK. For simplicity it is recommended to first use the RCTools from Radiocrafts since the USB VCP driver is included in this installation. Details on how to use this software is available from separate User Manuals.

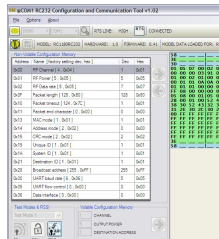

Figure 1: RC232-CCT, one of the applications in RCTools

### Development Kit Introduction

The Development Kit (DK) is designed to make it easy for the user to evaluate the onboard module, develop an application and build prototypes very quickly. The kit includes either two Development Boards (DB) or three DBs (for TinyMesh kits). The Development board contains the selected module with its dedicated article number and embedded protocol and associated support circuits. The board can easily be operated using a PC terminal emulator or the RCTools PC suite from Radiocrafts.

Your Development Kit should contain the following items:

Kit contents	
Item	Number of articles
Development Board w/high power radio module	2
Antenna, 50Ω quarter-wave monopole, SMA male connector	2
SMA to BNC adapters	2
USB Cable	2
AC/DC battery eliminator 6VDC	2

For TinyMesh™ Development Kits the number of articles is 3 of each item.

There are two different assemblies of the Development Board referenced in the rest of this document depending on the article number on the onboard RF module as summarized in the table below:

Development Boards	RC11xxHP-DB	RC12xxHP-DB	RC17xxHP-DB	RC16xxHP-DB
Supported Modules	RC11x0HP-RC232 RC11x0HP-TM	RC12x0HP-RC232	RC17xxHP-MBUS4  RC17xxMP-MBUS4  RC17xxHP-WIZE	RC1692HP-SIG

This User Manual describes how to use the Development Kit and provides detailed documentation for the Development Board.

The Development Kit includes what you need to evaluate the RF performance of the modules, develop your own application interfacing the modules, and can also be used to build a prototype of your application.

## Development Board Introduction

The Development Board contains USB connector, USB to serial converter, buttons, LEDs, voltage regulator, configuration jumpers and connectors to make it easy to interface the onboard module with various test equipment or the host MCU used in an application. Not all components are needed in an actual application. Please see the datasheet for each specific module for a typical application circuit.

The module on the Development Board is as default at power-up configured with a channel in the frequency band where high output power is allowed.

For RC1180HP-RC232 / -TM in particular: The allowed band for 500 mW (+27 dBm) operation is 869.400-869.650 MHz if configured for another channel, be sure to program the maximum allowed output power according to the datasheet, never exceeding +14 dBm outside the mentioned frequency band.

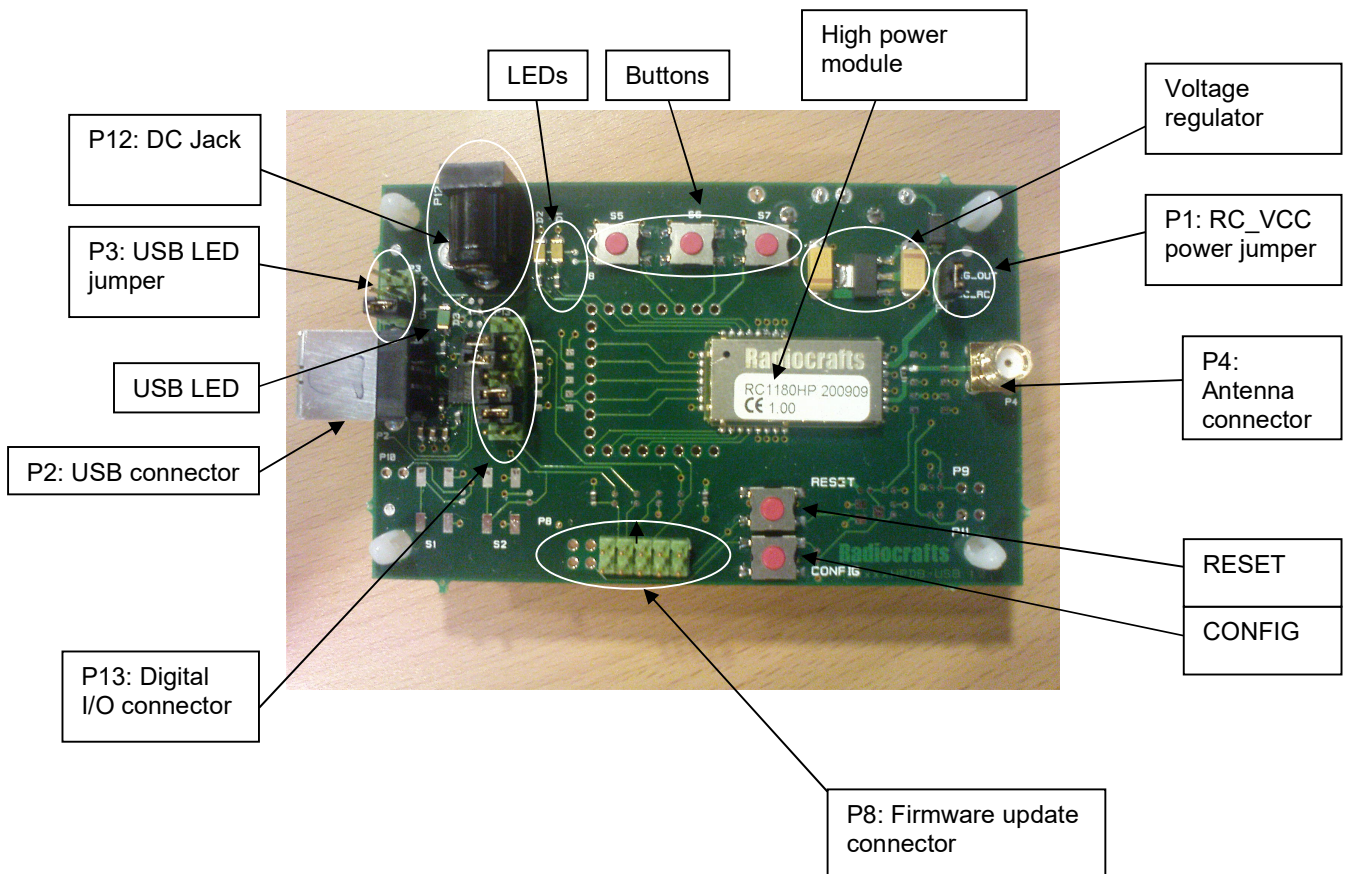
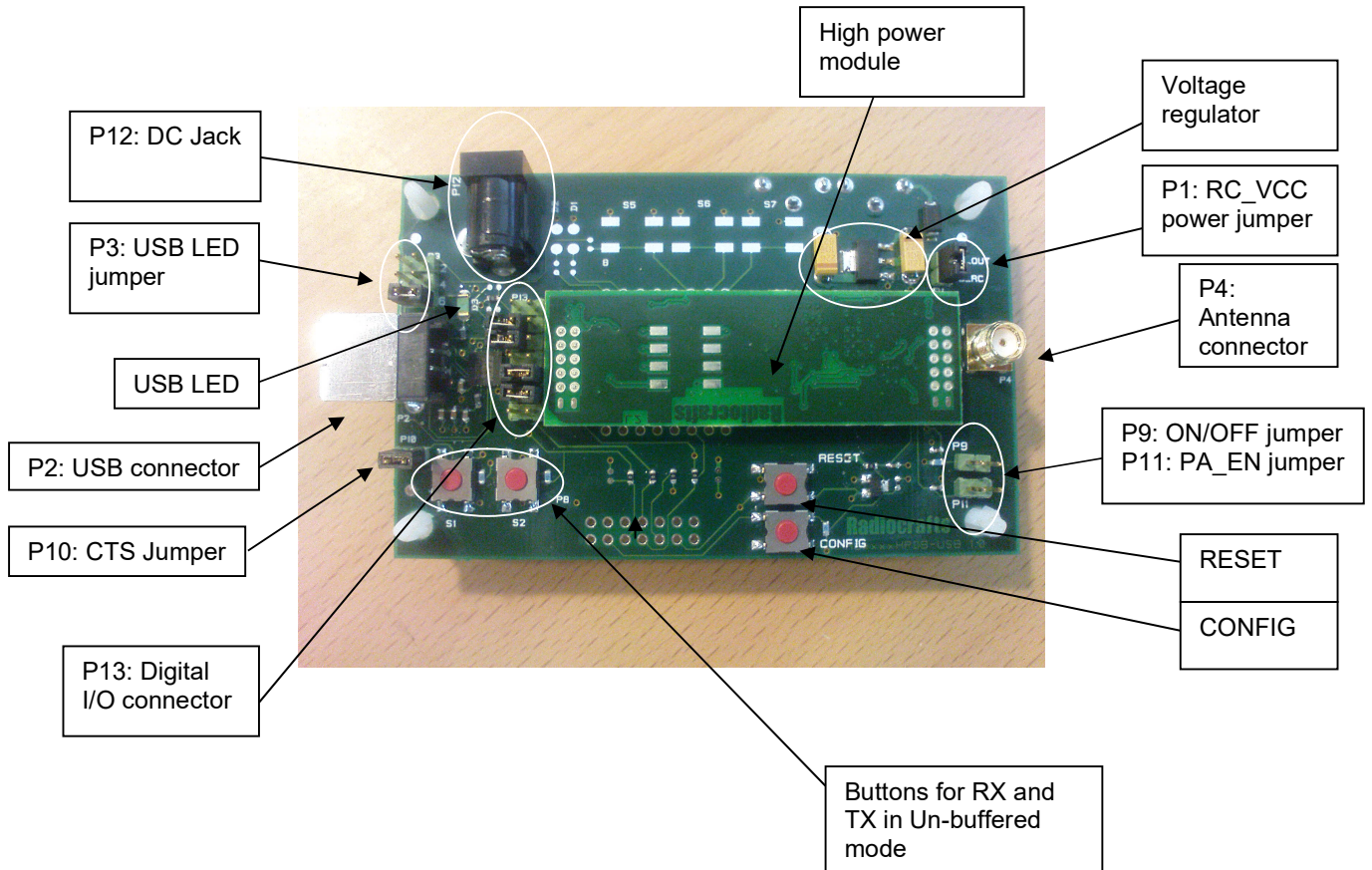
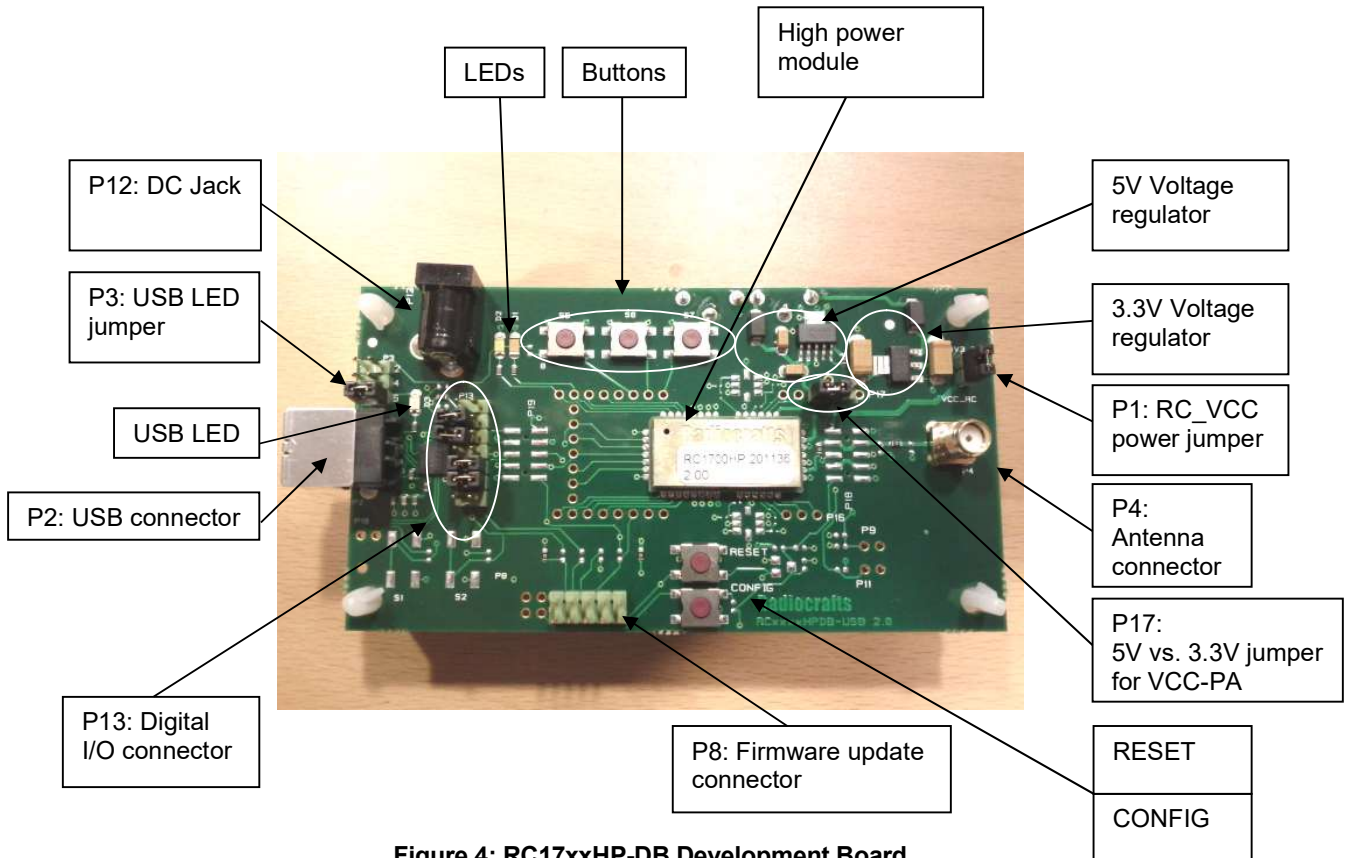

Figure 2: RC11xxHP-DB Development Board



**Figure 3: RC12xxHP-DB Development Board**



**Figure 4: RC17xxHP-DB Development Board**

## Block Diagram

The same PCB is used for all high-power modules previously mentioned. The component assembly is however different depending on which module is mounted. The block diagrams in figure 5-7 informs about actual parts used for a given Development board.

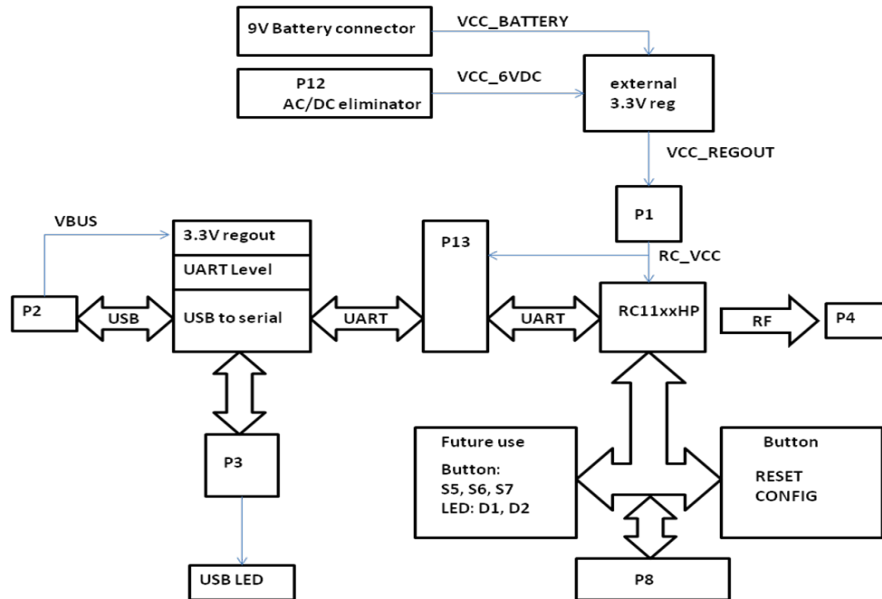

Figure 5: RC11xxHP-DB

LED D1 and LED D2 are activated on Development Boards with TinyMesh protocol. See TinyMesh Data Sheet for details.

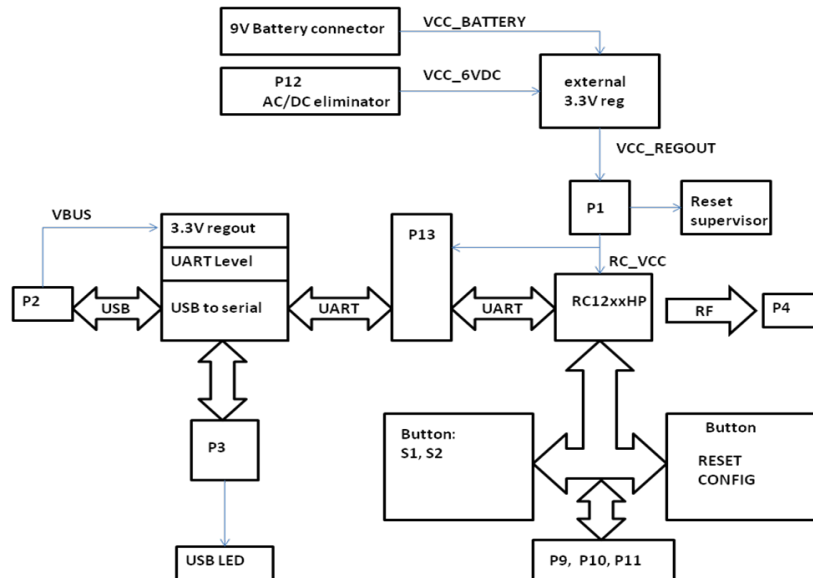

Figure 6: RC12xxHP-DB

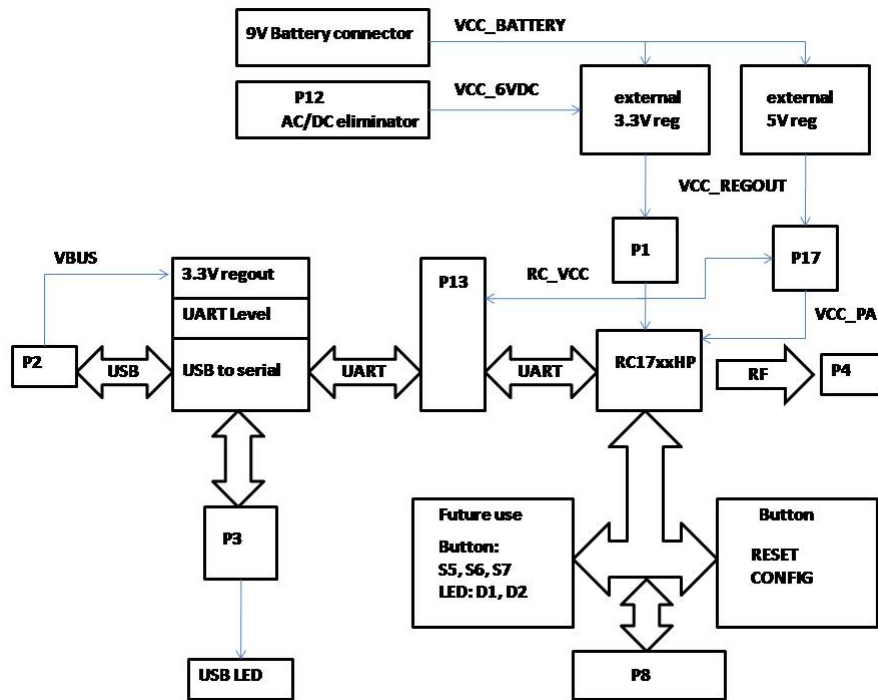

Figure 7: RC17xxHP-DB

### Jumper section

The board contains several jumper options for connector P1, P3, P9, P10, P11 and P13. The connectors and jumper settings are summarized in this chapter.

P1: UART voltage level jumper		
Pin #	Signal	Note
1	VCC_REGOUT	3.3V power from voltage regulator.
2	RC_VCC	Module Power. Connect jumper between pin 1 and pin 2 during normal IDLE, RX and TX operation. Replace jumper with Ampere meter for current consumption measurements.

P3: USB LED Jumper		
Pin #	Signal	Note
1	2	TXD Data
3	4	RXD data
5	6	POWER
		Install jumper to enable LED when Power is available from USB ( <b>default</b> ). LED current draw is typ 2.5 - 3.5 mA depending on RF module



P9: ON/OFF Jumper		
Pin #	Signal	Note
1	ON/OFF	Add jumper to enter OFF mode for RC12xxHP-DB. Not in use for RC11xxHP-DB
2	GND	

P10: CTS Jumper		
Pin #	Signal	Note
1	2	CTS
		Remove jumper for enabling CTS for RC12xxHP-DB. Not in use for RC11xxHP-DB

P11: PA_EN Jumper		
Pin #	Signal	Note
1	PA_EN	Add jumper to switch off high power PA for RC12xxHP-DB. Not in use for RC11xxHP-DB
2	GND	

P13: Digital I/O Connector		
Pin #	Signal	Note
1	2	VCC_REGOUT
		3.3V power from voltage regulator. Can be used to power external plug-in board.
3	4	CTS
		Install jumper when using hardware handshake
5	6	RTS
		Install jumper when using hardware handshake
7	8	CONFIG
		7 and 8 connected together. Connect pin 7 to pin 3 for PC control of CONFIG
9	10	TXD
		Jumper installed from factory Remove jumper when measuring sleep mode current
11	12	RXD
		Jumper installed from factory Remove jumper when measuring sleep mode current
13	14	GND

P17: VCC_PA Power Selection		
Pin #	Signal	Note
1	5V	5V regulator output
2	VCC_PA	RC1700HP selection only. Jumper to select between 5V and 3.3V power for internal PA.
3	3.3V	3.3V regulator output.

### Prototyping with the RCxxxxHP-DB

All pins to the module are available through standard pin rows using a pitch distance of 100 mil (2.54 mm). This simplifies the build of a standalone application just by making a small plug-in-board to the existing Development Board. Battery connectors on the bottom side are available for self powered demos, and REGOUT is available on P13. The Battery clips and most of the connectors are not mounted from factory, but part numbers are available from the Bill of Materials at the end of this document. The idea is that an external MCU and application specific sensors etc easily can be connected to the Development Board as a proof of concept for the final product.

### Antenna selection versus range performance

The choice of antenna is crucial for achieving the maximum range for any radio system. Due to the small size of the PCB and the off-centre placement of the onboard SMA connector the Development Boards will not demonstrate the maximum range or omnidirectional radiation. To improve this, a larger ground plane and a centred placement of the antenna above this ground plane is required. One possible solution for maximum radiation is shown in the figure below. With the addition of two different SMA adaptors and one sufficiently large ground plane (radius  $\geq L$ , length of the antenna) and a good electrical connection to the GND-layer, an optimum performance of the antenna following the kit is achieved.

Other antenna solutions can be tested by connecting to the existing SMA female connector on the Development Board via one of the methods below:

1. Solder the feeding point of the antenna to be tested directly to an SMA male connector and fasten to the SMA female connector
2. Connect to an external antenna (or board with antenna) via a shortest possible 50 Ohm coax cable with minimum insertion loss

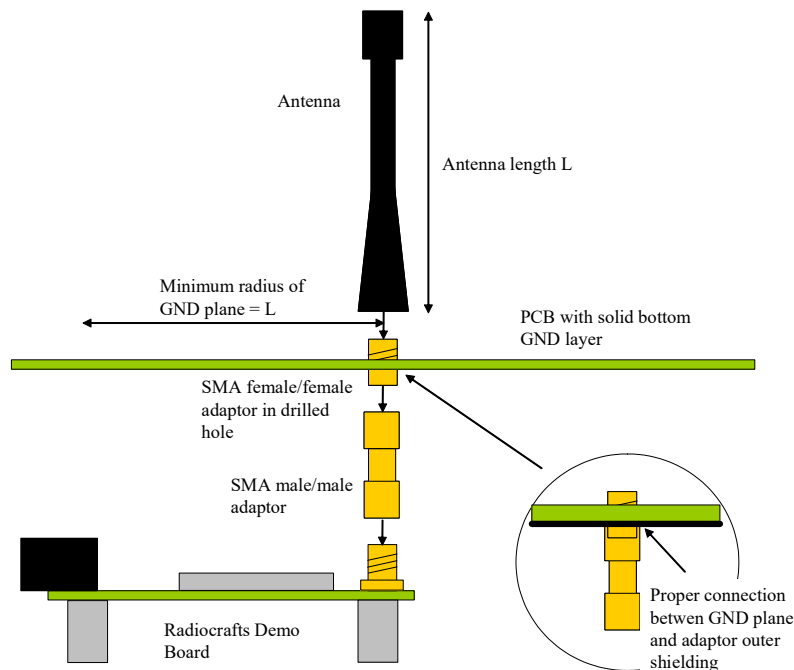

**Figure 7: Extending size of ground plane with extra PCB**

### RCxxxxHP-DB Circuit Diagram, PCB and Assembly layout

A full resolution schematic is found in RCxxxxHPDB\_x\_x.zip available from Radiocrafts' webpage. To download follow this link to download your revision of the board:

[https://www.radiocrafts.com/uploads/rcxxxxdbhp-usb\\_3\\_00.zip](https://www.radiocrafts.com/uploads/rcxxxxdbhp-usb_3_00.zip)

The dimension on the board are 73.66 mm x 45.72 mm. The PCB feet are BS-19S from AVC, which lifts the PCB 19.1mm from the table.

### Troubleshooting

*It doesn't work. The Power LED is not lighting.*

- Is the USB connector active? Some USB ports may be disabled if it's not commonly in use. The Development board takes power from the USB port, and need an active USB port to power the board.
- Are all jumpers placed at the default position? P3 can disable POWER LED info, and P9 can disable power to the module.

*I cannot communicate with the UART through the serial port*

- Make sure that the RXD and TXD jumpers are inserted on P13.
- Set up your terminal program according to the instructions in the Quick Start Guide. Remember to select the correct COM-port and connect to this port.
- Entering configuration mode (by press CONFIG button) the command prompt (“>”) should be displayed on the terminal window. Make sure to exit the command mode using the exit command (capital “X”).

*I cannot communicate between two modules in buffered mode*

- Make sure that the address mode and CRC mode is the same in both modules (set using the “M” Memory configuration command, refer to the RC232 User Manual).
- Make sure the destination address is the same as the other modules Unique ID if addressing is used (set using the “T” Destination address command, refer to the RC232 User Manual).
- Make sure to exit from command mode using capital “X”.
- The present configuration can be listed to the terminal using the test command “0” (zero).
- -SIG variants do not able to communicate with each other. For further details, please see the relevant User Manual.

*The module consumes more than the rated current in OFF and SLEEP mode*

- Note that the ON/OFF signal pull up resistor R2 (100 kΩ) draws approximately 27 uA. Remove this resistor when measuring the module current in OFF mode For RC12xxHPDB.
- Note that the level driver on the USB controller has common power as the module for default jumper setting. Remove P3 jumpers during the measurements.

*I cannot access configuration mode when I press the CONFIG button*

- Press and hold CONFIG button while pushing the RESET button (or power up the board). The reason you could not enter configuration mode, is most likely that some configuration memory values have been set to illegal values. List and check all values using the '0' (zero) command. Set all values back to default values (see RC232 User Manual or the respective Data Sheet).
- Note: If the mode is already in configuration mode it will not respond with another prompt if the CONFIG button is pressed. Send the '0' (zero) command to the module in order to check if it is already in configuration mode.

*I get unexpected results when measuring supply voltage with V-command*

- See *Known Issues* section

### Known Issues

HW Version	Issue
3.0 and earlier	The UART level from the FTDI-chip is always 3.3V. This work well when module is powered with 3.3 +/- 0.3V. Powering the module with external source <3.0V or >3.6V will create leakage current in UART input pins and give strange results for 'V' command, sleep current and so on.

### Document Revision History

Document Revision	Changes
1.0	First release
1.1	Updated with RC1700HP info
1.11	Updated with TinyMesh info (-TM)
3.01	Updated with SIGFOX info,
3.02	Updated link to schematics Added chapter "Known Issues"
3.03	Updated with WIZE info
3.04	Added mechanical dimensions of the Development Board. Removed USB in product name, kit and board are referred to as a Development Kit / Board.

### Disclaimer

Radiocrafts AS believes the information contained herein is correct and accurate at the time of this printing. However, Radiocrafts AS reserves the right to make changes to this product without notice. Radiocrafts AS does not assume any responsibility for the use of the described product; neither does it convey any license under its patent rights, or the rights of others. The latest updates are available at the Radiocrafts website or by contacting Radiocrafts directly.

As far as possible, major changes of product specifications and functionality will be stated in product specific Errata Notes published at the Radiocrafts website. Customers are encouraged to check regularly for the most recent updates on products and support tools.

### Trademarks

RC232™ is a trademark of Radiocrafts AS. The RC232™ Embedded RF Protocol is used in a range of products from Radiocrafts. The protocol handles host communication, data buffering, error check, addressing and broadcasting. It supports point-to-point, point-to-multipoint and peer-to-peer network topologies.

TinyMesh™ is a trademark of Tiny Mesh AS. The TinyMesh™ Embedded RF Protocol is used in a range of products from Radiocrafts. The protocol handles host communication, data buffering, error check, addressing and broadcasting. It supports transparent and packet-addressed mesh topologies.

All other trademarks, registered trademarks and product names are the sole property of their respective owners.

### Life Support Policy

This Radiocrafts product is not designed for use in life support appliances, devices, or other systems where malfunction can reasonably be expected to result in significant personal injury to the user, or as a critical component in any life support device or system whose failure to perform can be reasonably expected to cause the failure of the life support device or system, or to affect its safety or effectiveness. Radiocrafts AS customers using or selling these products for use in such applications do so at their own risk and agree to fully indemnify Radiocrafts AS for any damages resulting from any improper use or sale.

© 2011-2020, Radiocrafts AS. All rights reserved.

### Contact Information

Web site: [www.radiocrafts.com](http://www.radiocrafts.com)

Address:

**Radiocrafts AS**  
Sandakerveien 64  
NO-0484 OSLO  
NORWAY

Tel: +47 4000 5195

Fax: +47 22 71 29 15

E-mails: [sales@radiocrafts.com](mailto:sales@radiocrafts.com)  
[support@radiocrafts.com](mailto:support@radiocrafts.com)