

Embedded Piezoelectric Accelerometer (EPA)

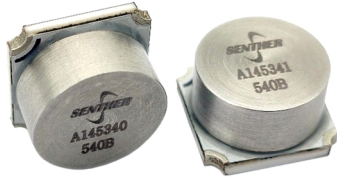

Patent pending

Features

- Annular shear structure
- Excellent long-term stability
- Voltage excitation/output
- Wide frequency response
0.5Hz to 28 kHz ($\pm 3\text{dB}$ point)
- Low noise: $8 \mu\text{g}/\sqrt{\text{Hz}}$ @1kHz
- Linearity $\pm 0.5\%$ up to 500g range
- Low power consumption: 0.06 mA
- -55°C to $+150^\circ\text{C}$ temperature range
- Sensitive orientation vertical
(To mounting surface)
- Wide acceleration range: 50~500g full scale
- Small Package $10\text{mm} \times 10\text{mm} \times 5.5\text{mm}$
- Reflow solderable

Application

- Condition monitoring
- Shock/impact data logger
- Bear/Gearbox embedded
- Machine vibration monitoring
- General test and measurement

Functional Block Diagram

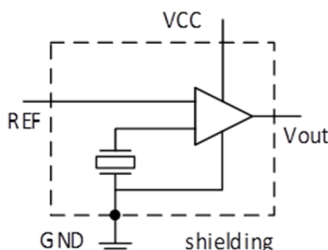

Figure 1

Description

The 540B is a miniature, low power consumption vibration sensor especially designed for embedded condition monitoring. With the latest piezo-electrical (PE) technology incorporated in the sensor, 540B vibration sensors provide superior signal-to-noise ratio and frequency response than the other technology devices. The annular shear PE structure delivers the super stable output, ultra-low noise density over an extended frequency range, which is optimized for industrial machine monitoring. 540B have typical noise densities of $8 \mu\text{g}/\sqrt{\text{Hz}}$ with $60\mu\text{A}$ current consumption. All series products have stable and repeatable sensitivity output which is immune to external shocks up to 5000g. 540B offer diversity mounting configuration for embedded applications. With wide range of voltage excitation from 3 to 30 Vdc, 540B also enable wireless sensing and plug-in product design. 540B are available in a $10\text{mm} \times 10\text{mm} \times 5.5\text{mm}$ SMD package, and are rated for operation over -55°C to $+150^\circ\text{C}$ temperature range.

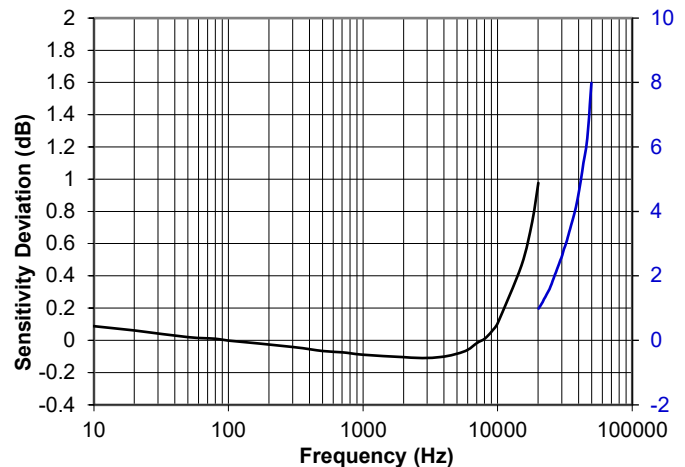

Figure 2 Typical Frequency Response

Table 1.

540 serials Accelerometer	
540A	low noise, noise density $4\mu\text{g}/\sqrt{\text{Hz}}$
540B	low power, supply current $60\mu\text{A}$

Specifications

T_A = 25°C, V_{CC} = 10 V, acceleration = 0 g, unless otherwise noted.

Table 2.

Parameter	Test Conditions/ Comments	540B			Unit
		Min.	Typ.	Max.	
SENSOR					
Measurement Range				±500	g
Linearity	Percentage of full scale		±0.5		%
Transverse Sensitivity			1	5	%
SENSITIVITY					
Sensitivity	100Hz, 10g, 25°C	4.5	5	5.5	mV/g
Sensitivity Change over Temperature	T _A = -40°C to +125°C		±5		%
BIAS					
0g Output Voltage	Refer to Vref	-0.4	0	0.4	V
0g Output Change over Temperature	-40°C to +125°C	-0.3		0.3	V
NOISE					
Noise Density	1 kHz		8		µg/√Hz
WARM UP TIME					
			1		s
FREQUENCY RESPONSE					
Sensor Resonant Frequency	Mounting on the lid with hard epoxy		>50		kHz
3 dB Bandwidth		0.5Hz		28kHz	
REFERENCE INPUT					
Input Voltage		0		V _{CC}	V
Input Current				±1	nA
OUTPUT					
Short-Circuit Current			0.06		mA
Output Impedance			10		KΩ
Minimum Resistive Load			1		MΩ
Maximum voltage output	Refer to V _{CC}	-0.8			V
Minimum voltage output	Refer to GND			0.8	V
POWER SUPPLY (V_{CC})					
Operating Voltage Range		3		30	V
Quiescent Supply Current			0.06	0.1	mA
OPERATING TEMPERATURE RANGE					
		-55		150	°C

Absolute Maximum Ratings

Table 3.

Parameter	Rating
Acceleration (Any Axials)	5,000 g
Drop Test (Concrete Surface)	2 m
VCC	-0.3 V to +40 V
Output Short-Circuit Duration (Any Pin to Common)	Indefinite
Temperature Range (Storage and operation)	-55°C to +150°C

Stresses at or above those listed under Absolute Maximum Ratings may cause permanent damage to the product. This is a stress rating only; functional operation of the product at these or any other conditions above those indicated in the operational section of this specification is not implied. Operation beyond the maximum operating conditions for extended periods may affect product reliability.

Thermal Resistance

Thermal performance is directly linked to printed circuit board (PCB) design and operating environment. Careful attention to PCB thermal design is required. θ_{JA} is the natural convection junction to ambient thermal resistance measured in a one cubic foot sealed enclosure. θ_{JC} is the junction to case thermal resistance.

Table 4. Package Characteristics

Package Type	θ_{JC}	θ_{JA}	Device Weight
SMD	25°C/W	15°C/W	1.8g

ESD Caution



ESD (electrostatic discharge) sensitive device. Charged devices and circuit boards can discharge without detection. Although this product features patented or proprietary protection circuitry, damage may occur on devices subjected to high energy ESD. Therefore, proper ESD precautions should be taken to avoid performance degradation or loss of functionality.

Recommended Soldering Profile

Figure 3 and Table 5 provide details about the recommended soldering profile.

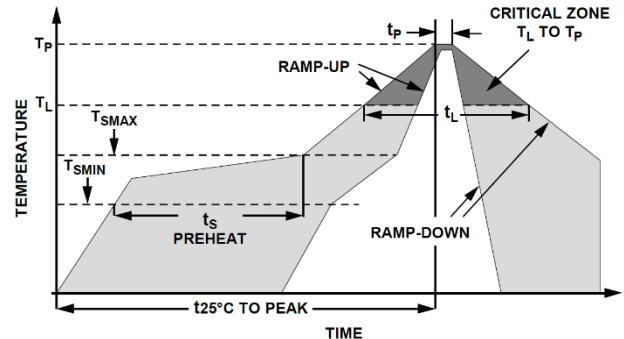

Figure 3 Recommended Soldering Profile

Table 5. Recommended Soldering Profile

Profile Feature	Condition	
	Sn63/Pb37	Pb-Free
Average Ramp Rate (T_L to T_P)	3°C/sec maximum	3°C/sec maximum
Preheat		
Minimum Temperature (T_{SMIN})	100°C	150°C
Maximum Temperature (T_{SMAX})	150°C	200°C
Time, T_{SMIN} to T_{SMAX} (t_S)	60 sec to 120 sec	60 sec to 180 sec
T_{SMAX} to T_L		
Ramp-Up Rate	3°C/sec maximum	3°C/sec maximum
Time Maintained Above		
Liquidous (T_L)		
Liquidous Temperature (T_L)	183°C	217°C
Time (t_L)	60 sec to 150 sec	60 sec to 150 sec
Peak Temperature (T_P)	240°C + 0°C/-5°C	260°C + 0°C/-5°C
Time Within 5°C of Actual Peak Temperature (t_P)	10 sec to 30 sec	20 sec to 40 sec
Ramp-Down Rate	6°C/sec maximum	6°C/sec maximum
Time 25°C to Peak Temperature ($t_{25°C}$)	6 min maximum	8 min maximum

Pin Configuration and Function Descriptions

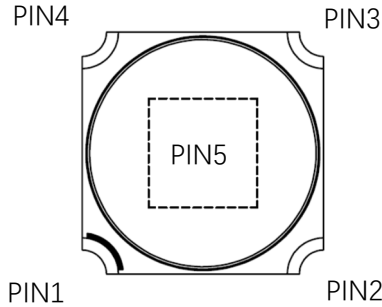

Figure 4 Pin Configuration

Table 6. Pin Function Descriptions

Pin No.	Mnemonic	Description
1	GND	Power Ground
2	V _{CC}	3V to 30V Supply Voltage
3	Vout	Voltage Output
4	REF	Reference Voltage Input for Bias Setting
5	GND	Bottom Pad for solder reinforce
/	Cover	Cover be connected to Power Ground

Typical Noise and Temperature Characteristics

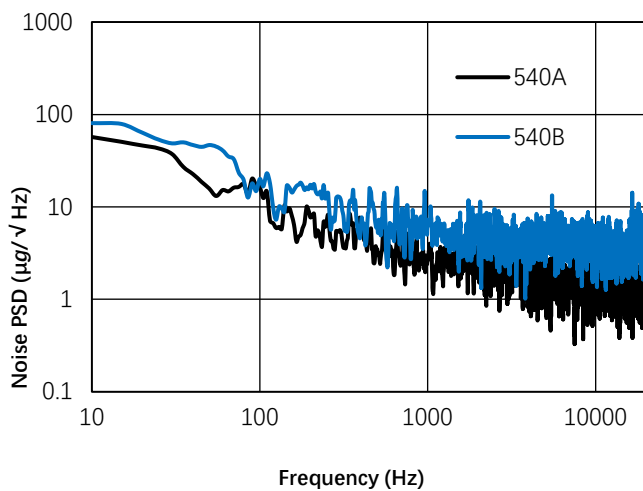

Figure 5 Noise Power Spectral Density (Noise PSD)

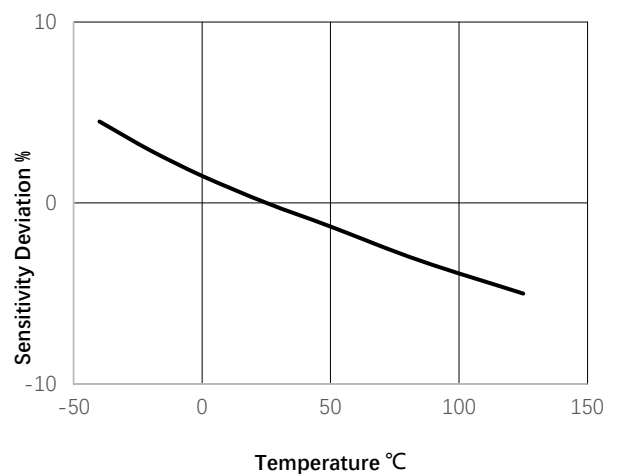

Figure 6 Typical Sensitivity temperature change

Application Note:

Power supply

The 540B can be powered from 3 to 30Vdc. For the most applications, a single 0.1~1 μF capacitor adequately decouples the accelerometer from noise on the power supply. Since the sensor's sensitivity was fixed, higher supply voltage will provide a wider output swing, then workable for higher acceleration range. Typically, 3.3V, 5V, 8V supplier serve 50g, 200g, 500g range. Higher supply voltage also works fine. Lower supply voltage may lead to higher nonlinearity.

Application circuit

Figure 7 is the typical application circuit.

This configuration requires a few external components. The JFET can be MMBF4117, 2N4117, PN4117 or equivalent. Bias output= $V_{CC} * 100k / (R1 + 100k)$. To get the widest output signal swing, the bias should be set to half of the supply voltage (V_{CC}).

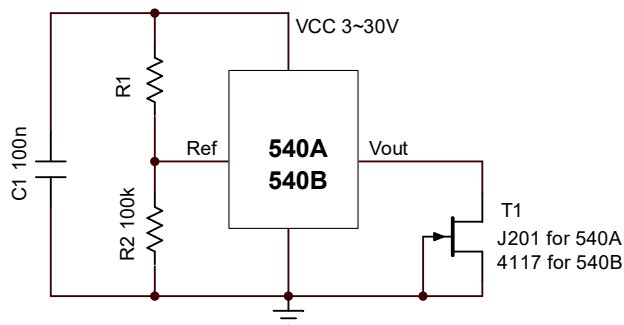

Figure 7 Typical circuit1

Figure 8 is the alternative application circuit.

This configuration replace JFET by a NPN pair, and consume higher current. T1 can be BCM846BS-7, PMP4201G135, BCM56DSF, NST45011MW6T1G or equivalent. $R3 = (V_{CC} - 0.7) / 0.06$ kohm.

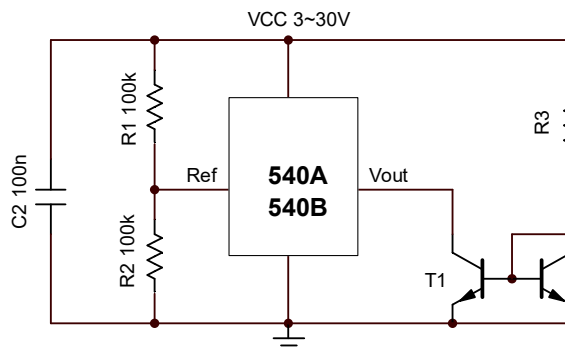

Figure 8 Typical circuit2

Figure 9 is the typical application with amplifier.

For specified application requires operational amplifier to get higher sensitivity. Make sure signal swing match the data acquisition circuit. Gain= $1 + 4.99k / R6$, Bias= $V_{CC} * Gain * 1M / (R3 + 1M)$. Apply larger Gain will increase noise level at the same time. Low noise amplifier is proposed for better signal-to-noise ratio.

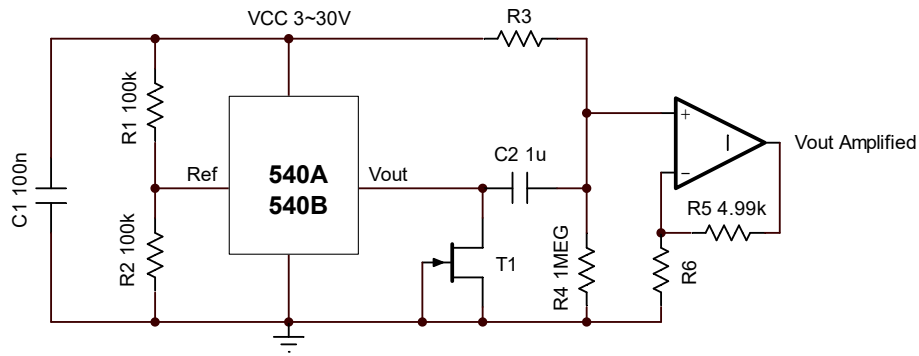

Figure 9 Typical circuit with amplifier

Output couple

Some data acquisition system requires symmetrical signal input refer to ground. In this case, a capacitor with value of 0.1~2.2uF should follow sensor output, which can couple AC signal to data acquisition circuit. See **figure 10**.

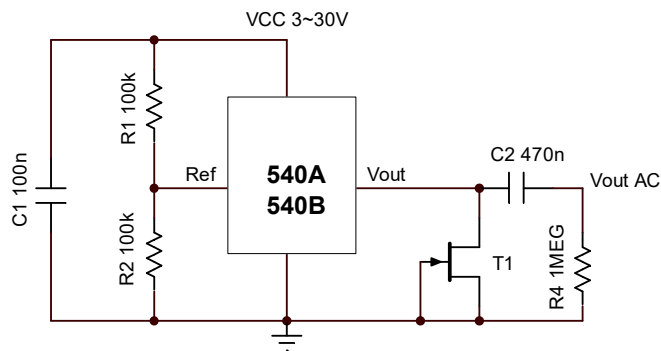

Figure 10 AC couple

Output filter

The 540B has no built in filter. A low pass filter with knee frequency lower than 20 kHz will help to attenuate resonance peak.

Quick wake up from sleep mode

Cycle power was used for power saving on most battery supplying device. Wake up time is important on this configuration. The 540B support quick wake up, which only require 10mS to active from sleep mode. **Figure 11** and **figure 12** shows two typical quick wake circuit. On **figure 11**, turn off T2 make sensor go sleep, turn on T2 can active sensor with very short delay. On **figure 12**, push up the net by I/O of MCU directly will make sensor go sleep, pull down the net can active sensor quickly. Configure I/O by OC mode is proposed. Sensor's current consumption is less than 1μA during sleep mode.

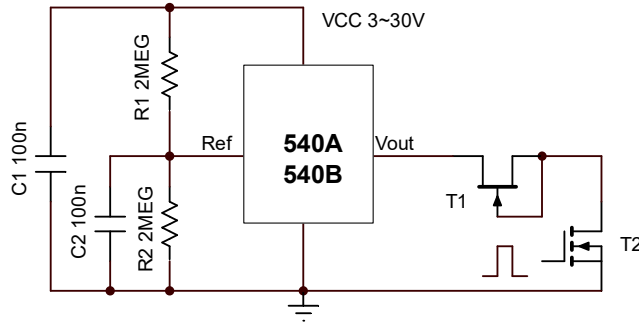

Figure 11 fast wake up setting1

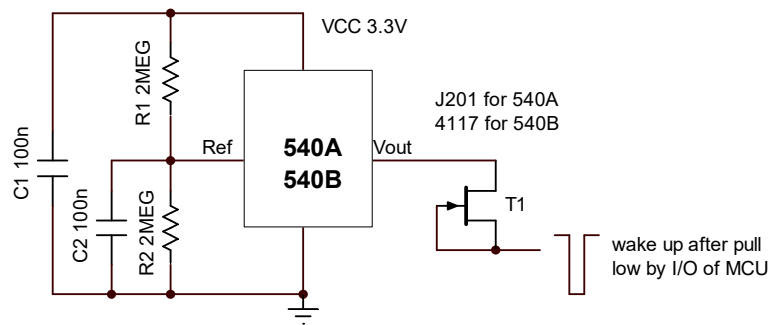

Figure 12 fast wake up setting2

Data acquisition

The output from 540B can be read by most of ADC directly, such as ADS131. **Figure 13** is a typical circuit. Set a suitable gain base on full scale output of sensor can get the best signal to noise ratio.

If the ADC has low input impedance, which require an operational amplifier to buffer the signal. See **figure 9**. Operational amplifier also be used to amplify signal to match input range of ADC. To achieve better performance, low noise operational amplifier is proposed, e.g. noise density below $10\text{nV}/\sqrt{\text{Hz}}$.

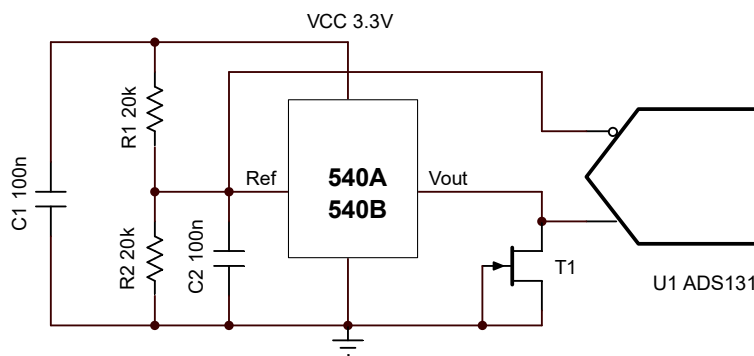

Figure 13 ADC circuit

Shielding

In case of 540B working under harsh electromagnetic environment, additional shielding is proposed to encase sensor and application circuit. Connect sensor shielding to the circuit ground is also proposed.

Mounting Note:

The 540B can be populated on PCB directly by SMT procedure. The central solder between sensor and PCB will help to achieve better performance on frequency response. See **figure 14**.

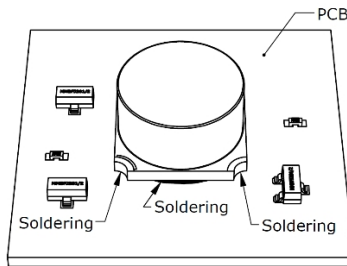

Figure 14

To achieve the best frequency response, attach the sensor on mounting surface by the lid is proposed. Solder light wire from sensor to the circuit and keep it short or anchor wire close to sensor will decrease micro resonance. When mounting sensor on lid upside-down, the phase response will be inverted. See **figure 15**

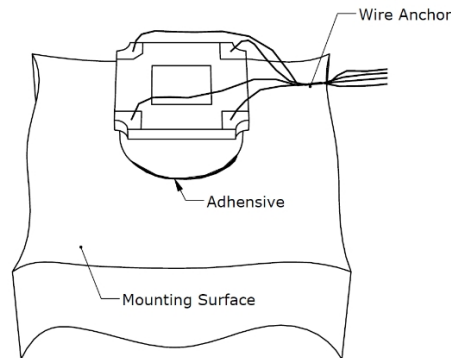

Figure 15

In case to attach sensor on a conductive surface, an insulating washer is proposed to be added between sensor and mounting surface, which avoid the grounding loop and keep signal clean. See **figure 16**

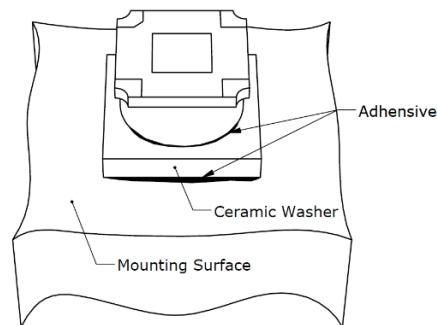

Figure 16

In case to embed sensor on an equipment, machine a mounting pit on the shell while avoid damaging the structural strength. Adhesive sensor with hard epoxy and potting for antifouling. See **figure 17**

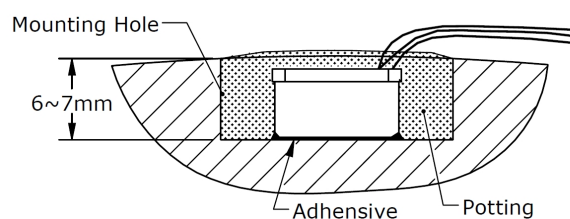

Figure 17

In case to encapsulate the sensor into a system, the frequency response is mainly decided by the method of mounting. Make sure robust mounting for high frequency application. See **figure 18** for frequency response by different mounting.

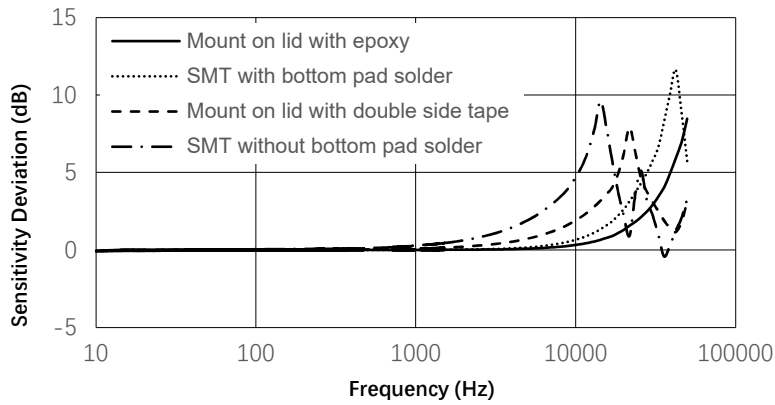

Figure 18

Outline Dimensions

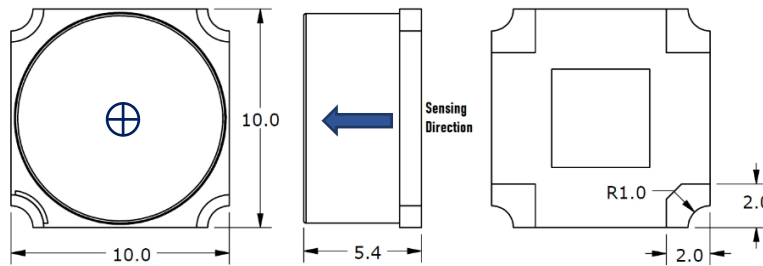

Figure 19 Outline Dimensions shown in millimeters

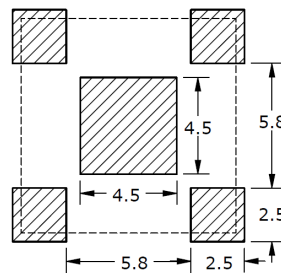

Figure 20 Recommended Soldering Footprint

Ordering Guide

Model	Max. g Range	Description	Package Option
540A	±500 g	540 chip piezo accelerometer high performance	4SMD
540B	±500 g	540 chip piezo accelerometer low power	4SMD

